

DYNAUDIO CAR



Esotar / Esotec
Mobile Loudspeaker systems

ESOTEC ESOTAR²

High-End Mobile Loudspeaker Systems



Dynaudio Automotive

The heart of Dynaudio's incredible performance has always been the high quality drivers the company has developed for its audiophile grade loudspeaker products, whether optimized for the Dynaudio home systems, professional or automotive product ranges.

A primary objective in the development of the first Dynaudio automotive loudspeaker models was to combine the qualitative performance attributes and off-axis response of the company's award-winning home audio models and the excellent near field response and refinement of the company's dedicated professional studio monitor products into a range of products that would be ideally suited to bring the advanced Dynaudio sound quality into the vehicle.

Designing a high-performance sound system for a car interior is far more complex and demanding as compared to developing a quality home audio system. Besides meeting the most fundamental objective – sound quality – the system must deal with other considerations such as extreme temperature variations, strong mechanical vibrations and greatly varying levels of ambient noise. Dynaudio determined that the only way to properly address this market was to develop a range of drivers with parameters specifically designed for and tailored to the car audio environment and its challenging acoustics.

Dynaudio's long-term, multi-million dollar research and development funded, car-acoustics optimized automotive loudspeaker models have always embodied the same advanced, no compromise approach that have rendered the company's home and professional product offerings as the absolute state-of-the-art.

The knowledge and experience gained under the constraints in developing the Dynaudio factory premium sound systems has tremendously benefited the evolution of the company's aftermarket sound systems, especially regarding tuning the crossovers and optimizing the drivers' parameters for the demands of a typical in-car installation. The available dedicated two-way or three-way adjustable crossover networks allow further fine-tuning and complete flexibility, allowing the drivers to realize their highest performance capabilities. Meanwhile, to accommodate more highly customized multi-driver installations, all Dynaudio Automotive drivers are available individually as separate components. All while delivering a level of sound quality performance that is instantly recognizable as that of a true Dynaudio loudspeaker system.

The Dynaudio Automotive loudspeaker models are the finest car audio loudspeaker models available. Embodying the most innovative and exclusive driver technologies, drawing from Dynaudio's latest advances in loudspeaker design, the Dynaudio Automotive products are more powerful, more refined, and more sophisticated than any other automotive loudspeaker offering, and set a new performance benchmark.

E S O T A R ²

High-End Mobile Loudspeaker Systems

Dynaudio Esotar²

Dynaudio loudspeakers are a unique combination of innovative technology, state-of-the-art manufacturing, and meticulous craftsmanship. The company has a history of producing exceptional loudspeaker products, assigning the now legendary "Esotar" moniker on its finest, most technically advanced, highest performance transducers. Thus it was only natural for Dynaudio to bestow its aftermarket automotive reference flagship loudspeaker range with the Esotar² designation.

Dynaudio has built its reputation of producing some of the best drivers available with its Esotar Home Systems models, and has now incorporated its most refined technological platform into a reference automotive speaker range worthy of the Esotar name. All three completely new Esotar² automotive separate drivers feature the highest level of Dynaudio transducer technology and deliver the best in-car sound quality ever offered from the company.

The highest grade materials, meticulous production quality, and precise fit and finish mated to Dynaudio's most advanced engineering results in a stunning sonic performance, allowing listeners to experience music like never before.

The new Esotar² automotive loudspeaker series represents the highest level of in-car music reproduction – not just for Dynaudio but for the entire world of mobile audio.

The Dynaudio Esotar² system, properly installed, will undoubtedly set new performance benchmarks.

Dynaudio has relied on soft dome tweeters for reproducing natural high frequencies since the company's origins, having perfected the soft dome principle. The Esotar tweeter design requires an extremely time-consuming labor intensive process where the fine fabric diaphragm is shaped into a dome and then treated with a special precision coating.

The best material for a tweeter is experience: Dynaudio has earned a reputation as a manufacturer of the finest high frequency drivers available with its venerable Esotar tweeters, and the company has incorporated its most refined technologies into the new Esotar² 110 reference automotive tweeter – which purely lives up to the Esotar designation by offering the most accurate, nuanced and detailed high frequency performance in the world. The Esotar² 110 represents the state-of-the-art in tweeter design while never exhibiting a shrill or harsh sonic character typical of metal or exotic material tweeter designs.

The Esotar² 110 tweeter features a specially coated 28 mm (1.1") diameter fabric dome, an ultra-lightweight voice coil, an extremely powerful neodymium magnet, and an exceptional CNC-machined metal housing with a newly-developed damping back chamber. The performance is highlighted by extremely high power handling, effortless reproduction of dynamics, absolute clarity, natural tonal balance and incredible resolution.

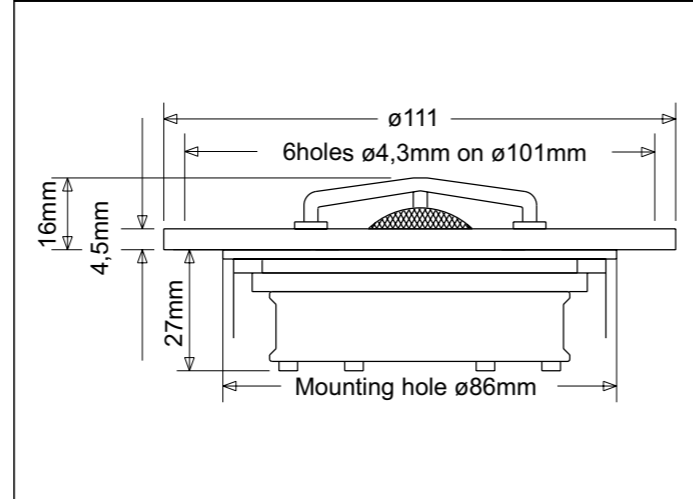

Thiele Small Parameters		
Nominal impedance	Znom	6 Ω
DC resistance	Re	5.2 Ω
Voice coil inductance	Le	- mH
Resonance frequency	fs	1000 Hz
Mechanical Q factor	Qms	-
Electrical Q factor	Qes	-
Total Q factor	Qts	-
Mechanical resistance	Rms	- kg/s
Moving mass (incl. air load)	Mms	- g
Suspension compliance	Cms	- mm/N
Effective dome diameter	d	3.1 mm
Effective piston area	Sd	7.7 cm ²
Equivalent volume	Vas	- l
Force factor	BL	- Tm
Recommended frequency range		2000–30000 Hz

Magnet and Voice Coil Properties		
Voice coil diameter	dc	28 mm
Voice coil height	hc	2.8 mm
Linear excursion, peak to peak		- mm
Max. excursion, peak to peak		- mm

Power Handling		
Nominal long term IEC		150 W
Transient (10 ms)		1000 W

Mechanical Properties		
Net weight		0.5 kg
Overall dimension		ø 111 x 41 mm

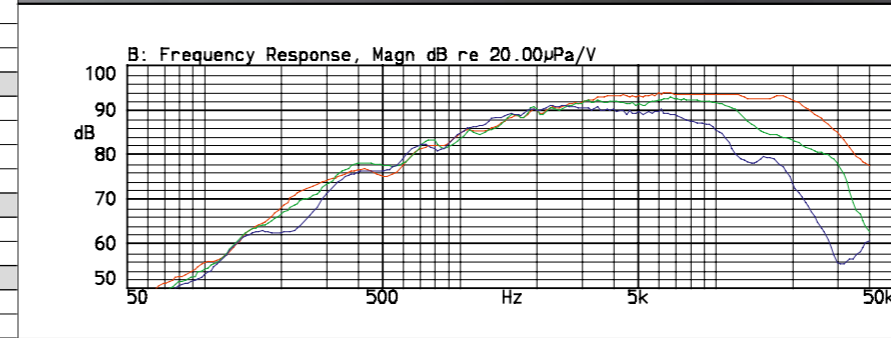
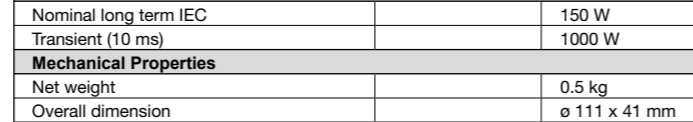

SPL
 Red line: on-axis response
 Green line: 30° horizontal
 Blue line: 60° horizontal
 Measurement conditions:
 Level: 2.83 V
 Distance: 1 m
 Measured in a large baffle

Facts
 Coated textile dome eliminates any high frequency break-ups
 Very strong neodymium magnet system with vented pole piece
 Open, spacious and detailed high frequency reproduction
 Excellent dynamic and transient performance

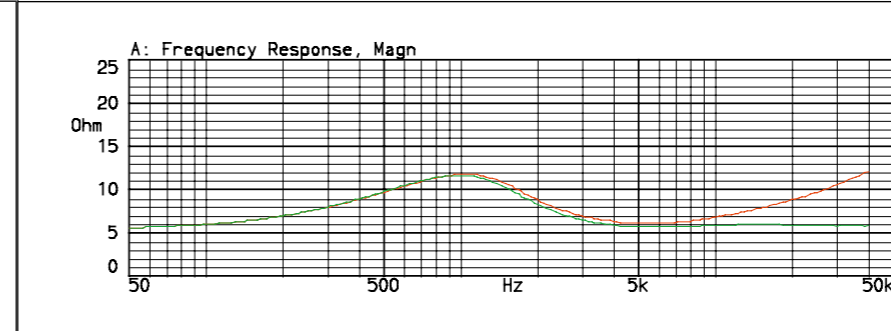

Impedance
 (with and without impedance correction circuit)
 Red line: impedance, free air
 Green line: impedance, free air with compensation.
 Measurement conditions:
 Level: 3.16 V, 50 ohm
 Driver in free air

Integrated damped cavity chamber in the pole piece
 Variovent integrated in back plate
 Ferrofluid adds damping and increases power handling
 Aluminium voice coil wire results in a low moving mass
 Shallow mounting depth

The new Esotar² 430 midrange features a geometrically optimized 3.5" diameter MSP (magnesium silicate polymer) cone, a material providing the ideal combination of stiffness, low weight and excellent inner damping.

The diaphragm and dust cap are molded as one piece. A new magnet/motor system incorporates powerful neodymium magnets and a large vented pole piece. The relatively large diameter aluminum voice coil wire provides for a low moving mass, and is wound on an aluminum former to maintain the extremely light weight.

Built into a rigid, die-cast solid aluminum frame with aerodynamically shaped ribs, in conjunction with the powerful motor, the characteristic Esotar² low-mass driver construction provides excellent transient response, speed and precision, with smooth high frequency roll off and a natural midrange reproduction. The Esotar² 430 driver exhibits very low distortion even at extreme volumes, while the transparency and detail of its midrange quality can best be described as holographic.

The Dynaudio Esotar² automotive loudspeaker series represent the highest level of automotive music reproduction – not just for Dynaudio but for the entire arena of mobile audio. The compact Dynaudio Esotar² 430 expands the possibilities for system installations with a performance that was previously not possible, and is a perfect complement to the performance benchmarks set by the Esotar² loudspeaker separates.

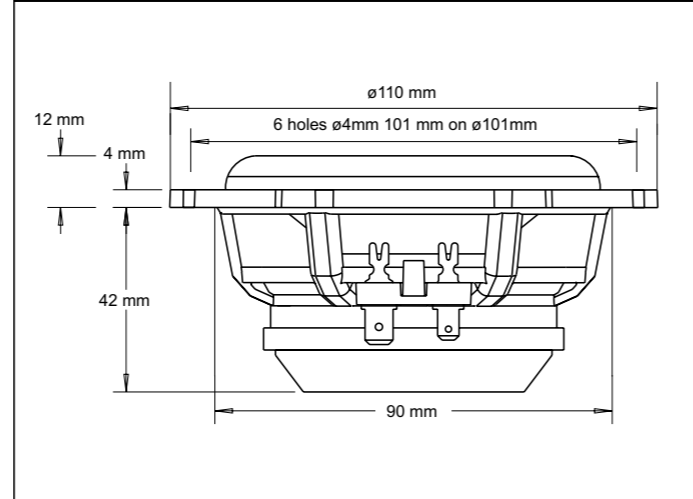

Thiele Small Parameters		
Nominal impedance	Znom	4 Ω
DC resistance	Re	4 Ω
Voice coil inductance	Le	0.19 mH
Resonance frequency	fs	64 Hz
Mechanical Q factor	Qms	1.5
Electrical Q factor	Qes	0.21
Total Q factor	Qts	0.18
Mechanical resistance	Rms	1.3 kg/s
Moving mass (incl. air load)	Mms	4.9 g
Suspension compliance	Cms	1.2 mm/N
Effective dome diameter	d	75 mm
Effective piston area	Sd	45 cm ²
Equivalent volume	Vas	3.5 l
Force factor	BL	6.2 Tm
Recommended frequency range		200–7000 Hz

Magnet and Voice Coil Properties		
Voice coil diameter	dc	34 mm
Voice coil height	hc	9.5 mm
Linear excursion, peak to peak		4.9 mm
Max. excursion, peak to peak		21 mm

Power Handling		
Nominal long term IEC		150 W
Transient (10 ms)		1000 W

Mechanical Properties		
Net weight		0.47 kg
Overall dimension		ø 110 x 49 mm

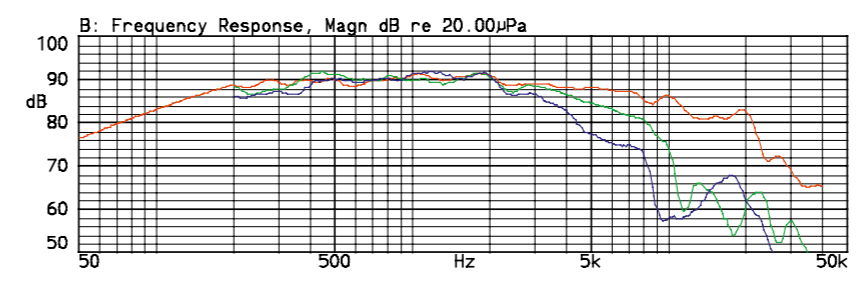
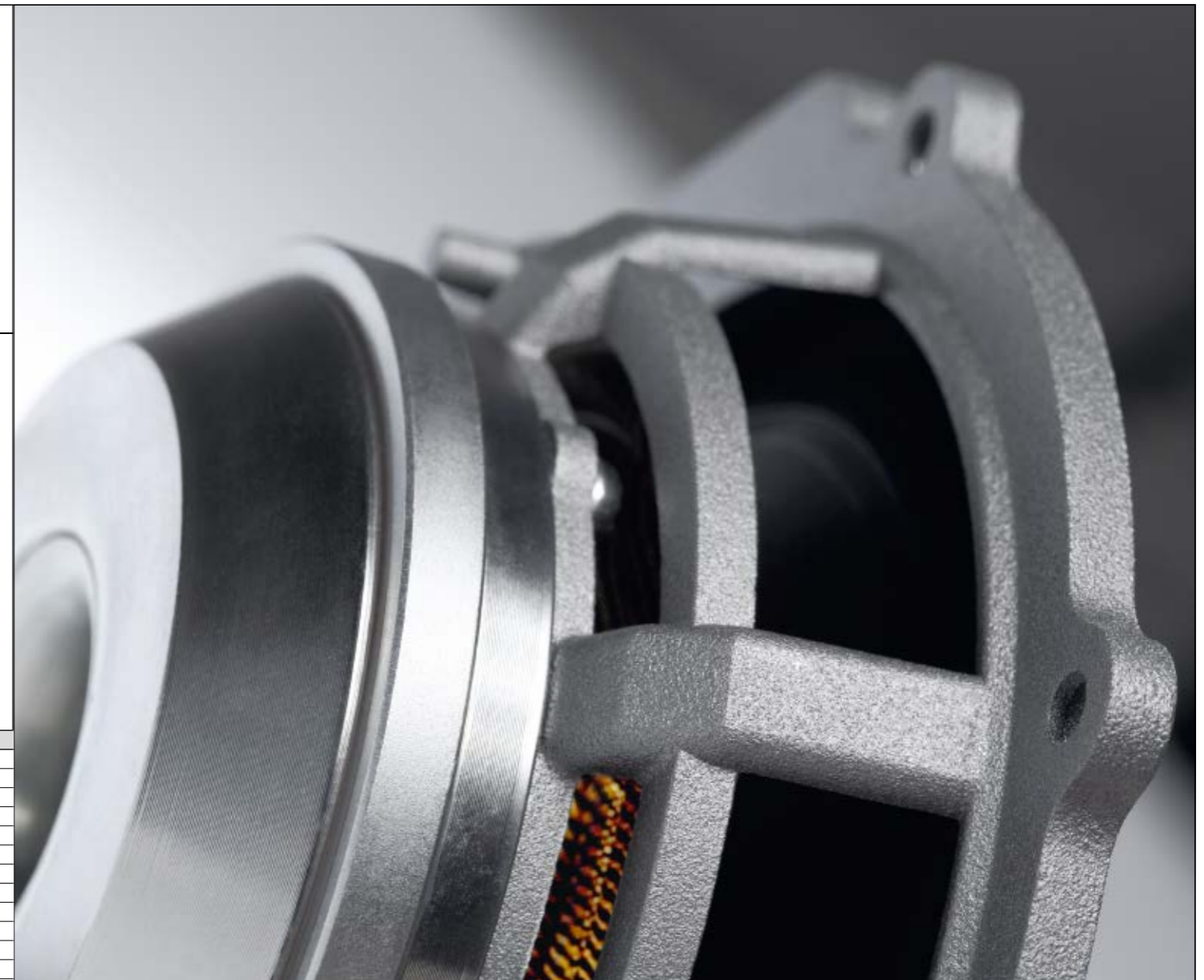
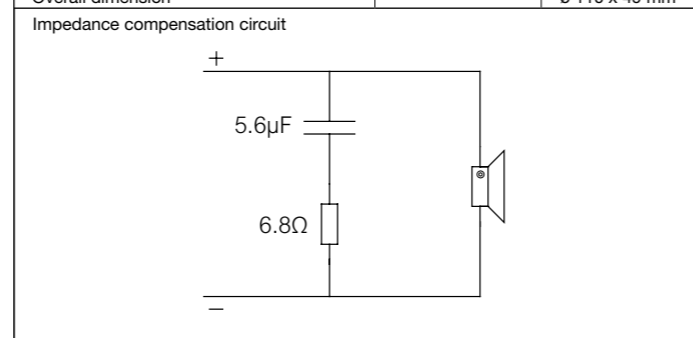

SPL
 Red line: on-axis response
 Green line: 30° horizontal
 Blue line: 60° horizontal
 Measurement conditions:
 Level: 2.83 V
 Distance: 1 m
 Box volume: 4 l

Facts
 Diaphragm and dust cap moulded as one piece
 Internal double neodymium magnet system with vented pole piece
 Aluminium voice coil wire provides for a low moving mass, wound on aluminium former
 Rigid die-cast chassis with aerodynamically shaped ribs

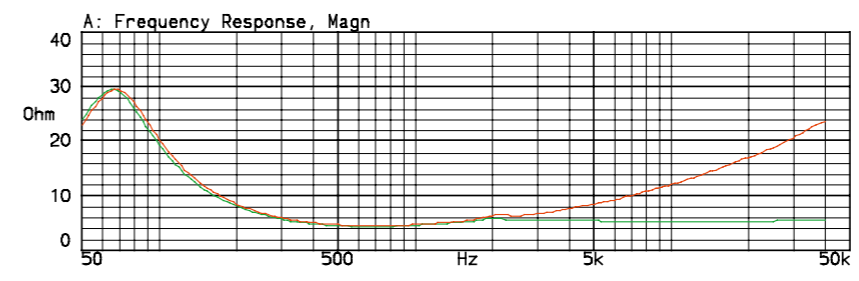

Impedance
 (with and without impedance correction circuit)
 Red line: impedance, free air
 Green line: impedance, free air with compensation.
 Measurement conditions:
 Level: 3.16 V, 50 ohm
 Driver in free air

Materials and parameters are optimized for the harsh environmental conditions in a car
 Smooth high-frequency roll-off
 Natural midrange reproduction

The Esotar² 650 is a 17 cm (6.5") diameter mid/bass driver that is built on a rigid, die-cast solid aluminum frame and features Dynaudio's characteristic MSP (Magnesium Silicate Polymer) diaphragm.

The MSP cone is a proprietary Dynaudio innovation, made in-house and featuring precisely-shaped, geometrically-optimized form to enable the smooth, optimized sound dispersion.

The voice coil diameter is exceptionally large at 75 mm, but by using extremely light aluminum wire wound on a Kapton former, the coil remains extremely lightweight to enable ultra-fast movement. The large coil enables the magnet to be positioned inside the coil, allowing for a larger and more homogenous magnetic field to be utilized. In conjunction with the incredibly powerful, high-efficiency neodymium magnet, this low-mass driver construction provides excellent transient response, incredible speed and unmatched precision.

When used as part of a two-way speaker system, the midrange resolution of the Esotar² 650 is simply beyond reproach; mid-bass remains taut and accurate while always exhibiting perfect control at all volume levels.

The Esotar² 650 perfectly reflects the innovation and performance that have established the Dynaudio Esotar drivers as the most advanced high-performance transducers available.

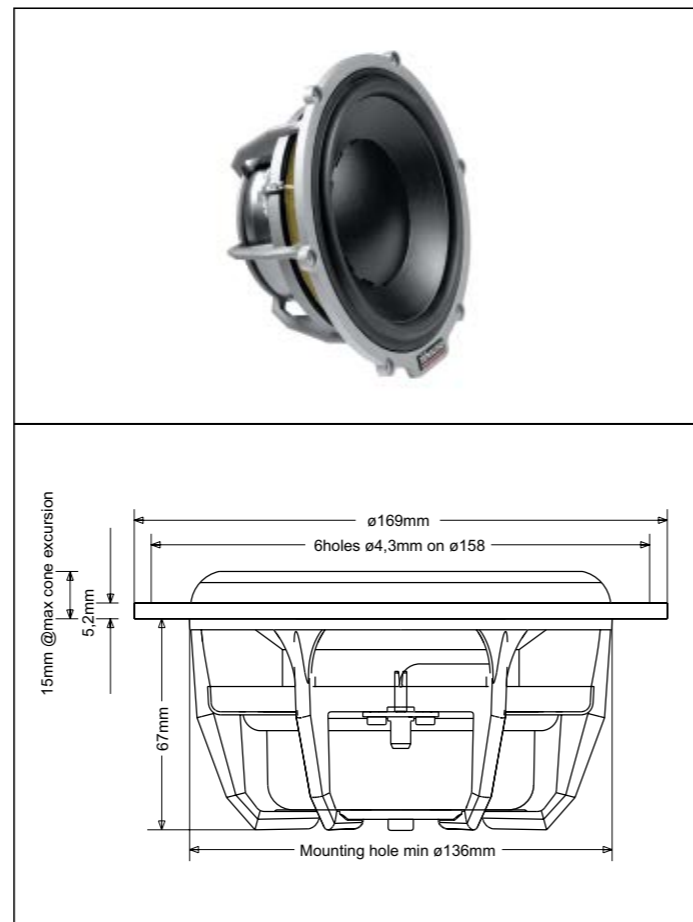

Thiele Small Parameters		
Nominal impedance	Znom	4 Ω
DC resistance	Re	3.4 Ω
Voice coil inductance	Le	0.33 mH
Resonance frequency	fs	49.6 Hz
Mechanical Q factor	Qms	6.2
Electrical Q factor	Qes	0.47
Total Q factor	Qts	0.44
Mechanical resistance	Rms	1 kg/s
Moving mass (incl. air load)	Mms	20 g
Suspension compliance	Cms	0.52 mm/N
Effective dome diameter	d	123 mm
Effective piston area	Sd	120 cm ²
Equivalent volume	Vas	10.5 l
Force factor	BL	6.73 Tm
Recommended frequency range		50–4000 Hz

Magnet and Voice Coil Properties		
Voice coil diameter	dc	75 mm
Voice coil height	hc	14 mm
Linear excursion, peak to peak		9 mm
Max. excursion, peak to peak		21 mm

Power Handling		
Nominal long term IEC		200 W
Transient (10 ms)		1000 W

Mechanical Properties		
Net weight		1.25 kg
Overall dimension		ø 169 x 78 mm

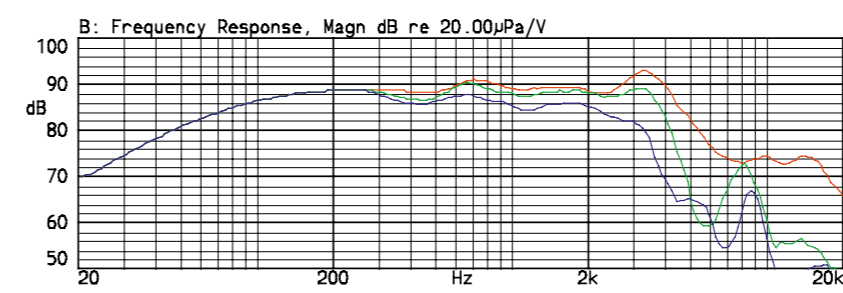
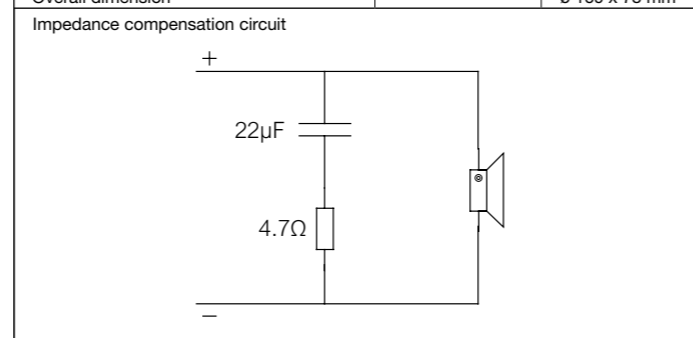

SPL
 Red line: on-axis response
 Green line: 30° horizontal
 Blue line: 60° horizontal
 Measurement conditions:
 Level: 2.83 V
 Distance: 1 m
 Box volume: 15.6 l

Facts
 Diaphragm and dust cap moulded as one piece
 Large 75 mm voice coil ensures high power handling
 Internal double neodymium magnet system with vented pole piece
 Aluminium voice coil wire provides for a low moving mass, wound on kapton former in a car
 Rigid die-cast chassis with aerodynamically shaped ribs
 Materials and parameters are optimized for the harsh environmental conditions in a car
 Smooth high-frequency roll-off
 Natural midrange reproduction

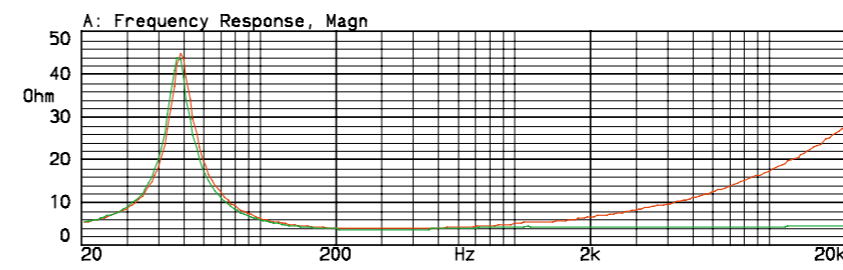

Impedance
 (with and without impedance correction circuit)
 Red line: impedance, free air
 Green line: impedance, free air with compensation.
 Measurement conditions:
 Level: 3.16 V, 50 ohm
 Driver in free air

The Esotar² 1200 Subwoofer features a unique construction: a massive dual-stacked magnet system powers a large 75 mm diameter aluminum voice coil and MSP cone diaphragm.

Dynaudio's exclusive MSP material provides the ideal combination of rigidity, light weight and excellent inner damping to naturally reproduce the lowest frequencies without distortion. The Esotar² 1200 utilizes an ultra-rigid die cast frame basket to ensure the most anti-resonant foundation of a powerful, accurate and controlled bass response.

Thanks to the innovative Dynaudio construction with precise parameters and extremely tight tolerances, this newly-designed 30 cm (12") diameter woofer has been optimized to achieve the most advanced sub-bass performance. And due to the very low distortion and an amazingly quick rise response, the Esotar² 1200 is also extremely easy to seamlessly integrate into any high performance autosound system.

Combining powerful yet deep bass performance with incredible extension down to 18 Hz, the Esotar² 1200 reproduces the highest sound pressure levels down to the lowest notes by precisely following the amplifier's signal, even at the highest output levels.

The Esotar² 1200 brings Dynaudio's most sophisticated engineering and development into the world of automotive subwoofer systems to establish another car audio industry benchmark.

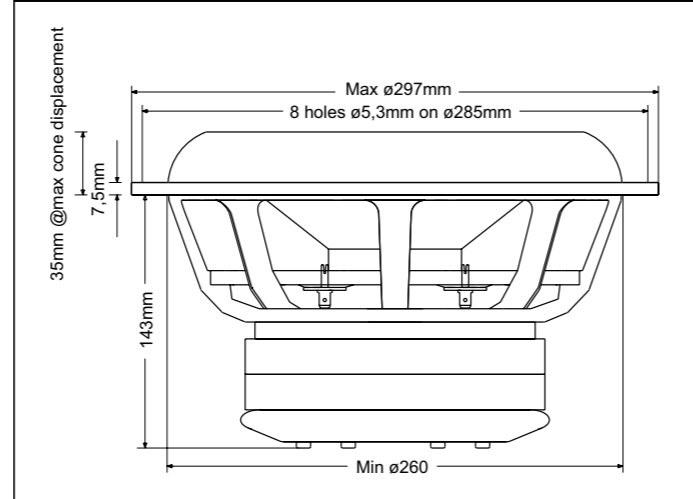

Thiele Small Parameters		
Nominal impedance	Z _{nom}	4 Ω
DC resistance	R _e	3.3 Ω
Voice coil inductance	L _e	1.1 mH
Resonance frequency	f _s	18.7 Hz
Mechanical Q factor	Q _{ms}	3
Electrical Q factor	Q _{es}	0.4
Total Q factor	Q _{ts}	0.34
Mechanical resistance	R _{ms}	4.4 kg/s
Moving mass (incl. air load)	M _{ms}	114 g
Suspension compliance	C _{ms}	0.64 mm/N
Effective dome diameter	d	233 mm
Effective piston area	S _d	425 cm ²
Equivalent volume	V _{as}	163 l
Force factor	BL	11.1 Tm
Recommended frequency range		18–300 Hz

Magnet and Voice Coil Properties		
Voice coil diameter	dc	75 mm
Voice coil height	hc	30 mm
Linear excursion, peak to peak		20.5 mm
Max. excursion, peak to peak		58 mm

Power Handling		
Nominal long term IEC		400 W
Transient (10 ms)		1500 W

Mechanical Properties		
Net weight		8.8 kg
Overall dimension		ø 297 x 162 mm

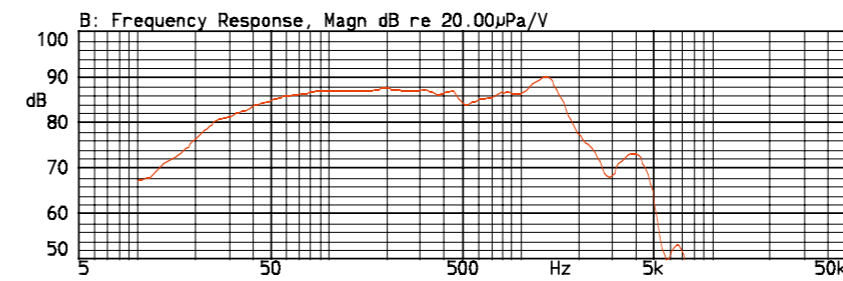
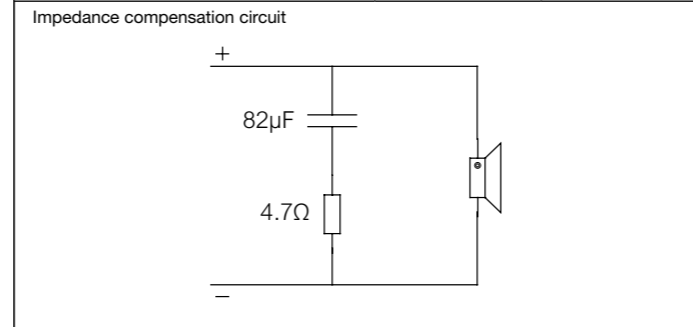

SPL
 Red line: on-axis response
 Measurement conditions:
 Level: 2.83 V
 Distance: 1 m
 Box volume: 71 l

Facts
 Large 75 mm voice coil ensures high power handling
 Diaphragm with very high excursion, 58 mm peak-to-peak
 High power handling, 400W long term IEC
 Rigid die-cast chassis with aerodynamically shaped ribs

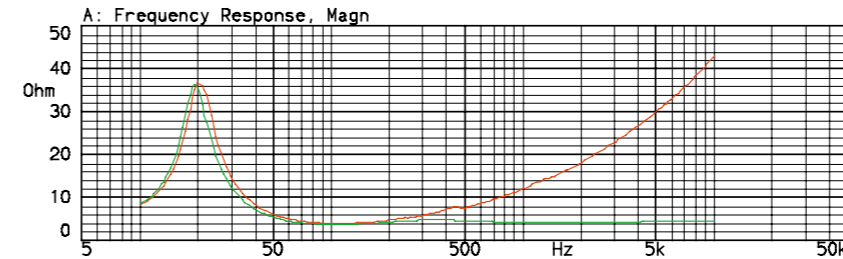

Impedance
 (with and without impedance correction circuit)
 Red line: impedance, free air
 Green line: impedance, free air with compensation.
 Measurement conditions:
 Level: 3.16 V, 50 ohm
 Driver in free air

Materials and parameters are optimized for the harsh environmental conditions in a car

Esotar² Passive Crossovers

It is not just technology that distinguishes a Dynaudio Esotar² automotive loudspeaker from conventional offerings; it is also the fine tuning. And just as each Esotar² driver has been meticulously fine-tuned, so have the Dynaudio Esotar² crossovers.

Only the finest quality components are utilized throughout the Dynaudio Esotar² passive crossovers, including newly developed flat ceramic resistors to further minimize component interaction where needed. Each features impedance correction while offering selectable level adjustments for the tweeter. The Dynaudio Esotar² crossovers facilitate a wide range of systems and applications, and are optimized for perfect phase response and time coherency in any vehicle. Only the highest quality components selected solely on the basis of their sonic properties are utilized. The extreme fine-tuning and complete flexibility of the Esotar² crossovers allow the Esotar² automotive loudspeaker drivers to realize the full extent of their highest performance capabilities.

Esotar² EX2-430

The Dynaudio Esotar² EX2-430 is an audiophile quality two-way passive crossover set designed for the integration of a reference automotive stereo system comprising a pair each of the Dynaudio Esotar² 110 tweeters and Esotar² 2 430 mid/range drivers.

A Dynaudio Esotar² 1200 subwoofer (as well as the Dynaudio Esotec MW 172 or Esotec MW 182 woofers if desired) can be added in an active system configuration.

Esotar² EX2-650

The Dynaudio Esotar² EX2-650 is an audiophile quality two-way passive crossover set.

It is designed for the integration of a reference automotive stereo system comprising a pair each of the Esotar² 110 tweeters and Esotar² 650 mid/woofers.

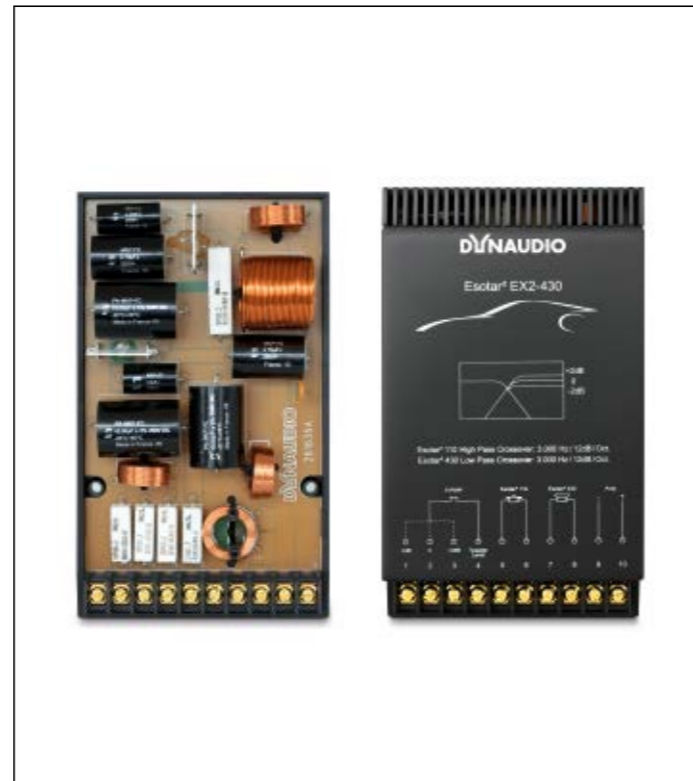

EX2-430	Esotar ² 430
Crossover frequency	3000 Hz
Nominal impedance	4 Ohms
Dimensions	43 x 102 x 173 mm
Net weight	0.5 kg

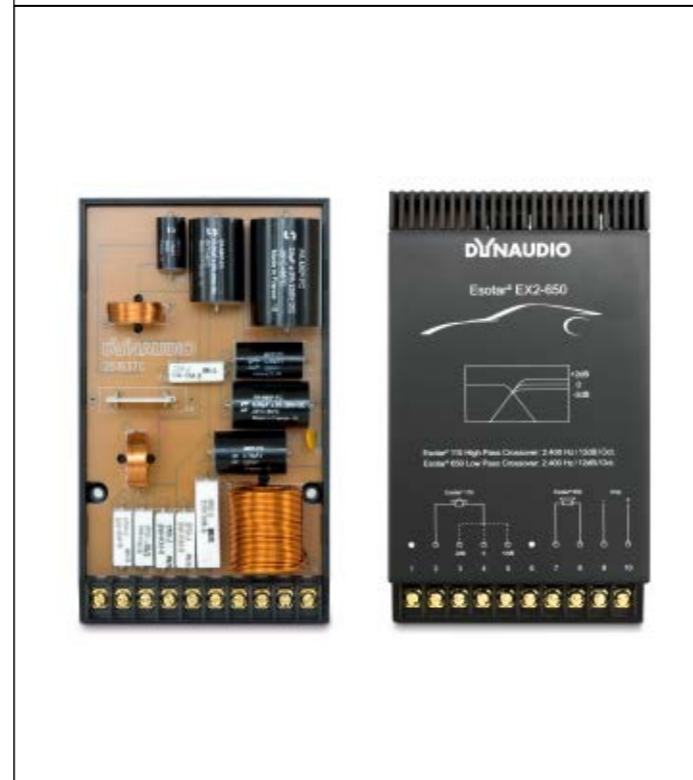

EX2-650	Esotar ² 650
Crossover frequency	2.400 Hz
Nominal impedance	4 Ohms
Dimensions	43 x 102 x 173 mm
Net weight	0.5 kg

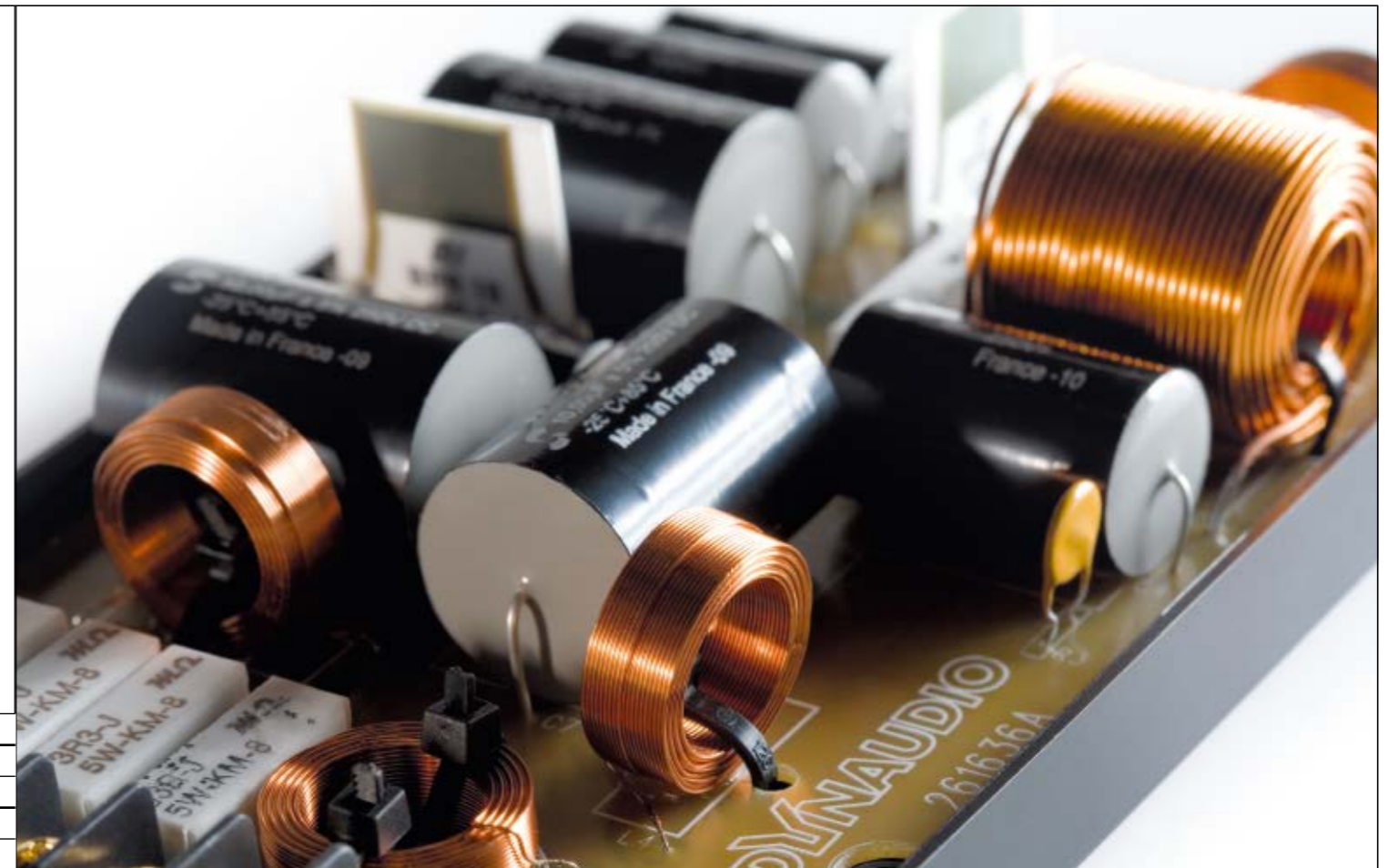

Esotar² EX3-650 (HF/LF)

The Dynaudio Esotar² EX3-650 is an audiophile quality three-way passive crossover designed for the integration of a reference automotive three-way system comprised of an Esotar² 110 tweeter, Esotar² 430 midrange, and Esotar² 650 mid/woofer.

The EX3-650 is a two-box per channel crossover solution that allows for bi-amping. For a stereo system installation, a second EX3-650 crossover (as well as a second unit of each Esotar² driver) would be needed. An Esotar² 1200 subwoofer may also be added in a fully active system.

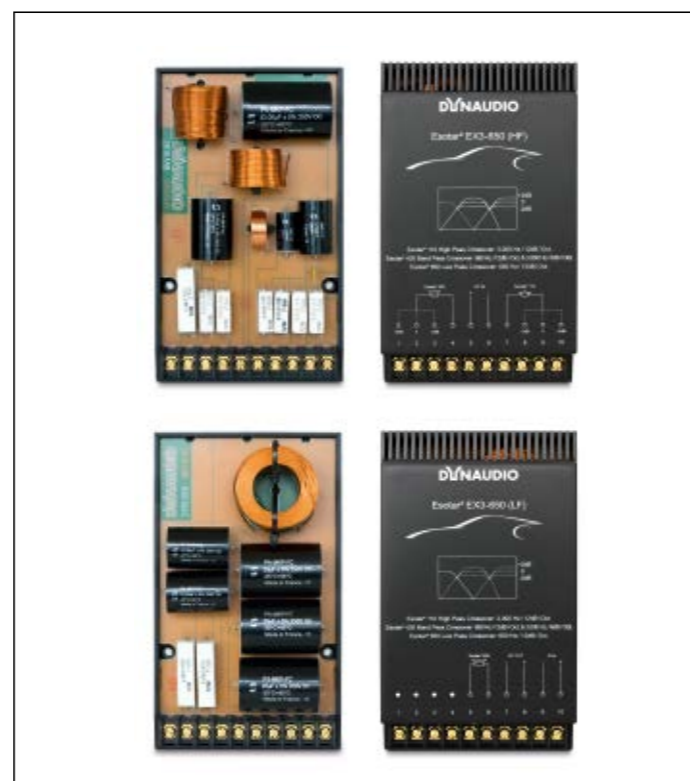

EX3-650

Crossover frequency	650 Hz/3.000 Hz
Nominal impedance	4 Ohms
Dimensions	43 x 102 x 173 mm
Net weight	0.5 kg (HF) / 0.6 kg (LF)

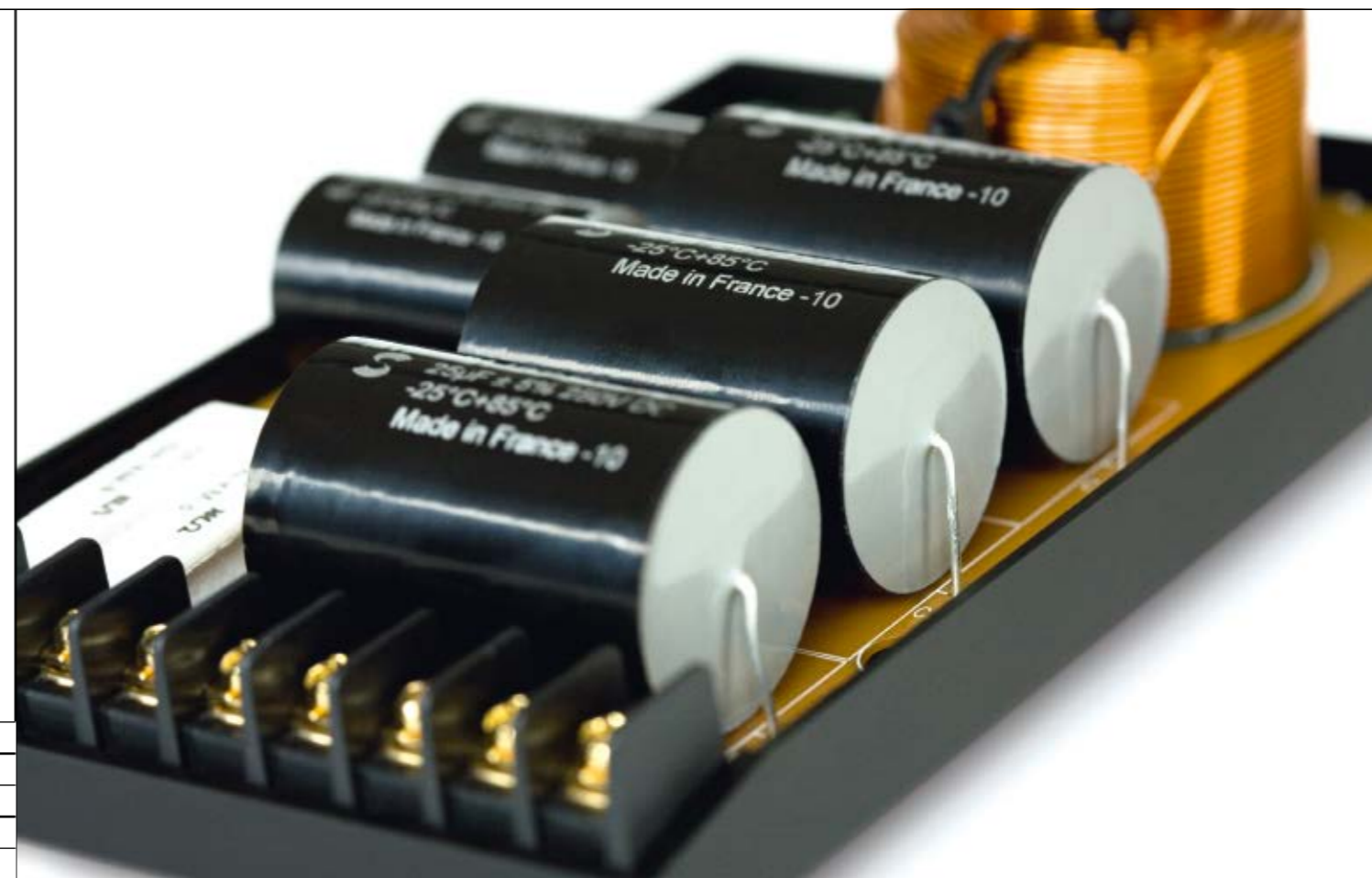

Esotar² Trim Rings

The Dynaudio Esotar² drivers are reference-level loudspeaker components capable of revealing even the most subtle sonic details. To achieve a superb level of sound quality, however, one must pay attention to the quality of installation and ancillary equipment. The ultimate level of performance realized will depend heavily on the above, and there are many points to consider.

To achieve the highest level of sound quality, it is very important that the loudspeakers are mounted to solid and well-damped baffles and that the air space behind the woofers is sealed from the vehicle interior. To avoid rattles and resonance, it is important that surfaces such as inner door skins, surrounding metal and even exterior panels are reinforced and damped with quality sound/vibration deadening materials.

The Esotar² driver frame features a unique bolt pattern with the mounting holes on the perimeter of the frame (high grade mounting bolts are included). To conveniently facilitate flush-mount installations, Dynaudio offers dedicated installation trim rings featuring CNC machined precision cut-outs that perfectly fit the outline of the Esotar² driver frames.



Available for:	- Esotar ² 110
	- Esotar ² 430
	- Esotar ² 650
	- Esotar ² 1200



E S O T E C

High-End Mobile Loudspeaker Systems

Dynaudio Esotec

A primary objective in the development of the Dynaudio automotive loudspeaker models was to combine the qualitative performance attributes and off-axis response of the company's award-winning home audio models with the excellent near field response of the company's dedicated studio monitors into a range of mobile audio products that would be ideally suited to bring the advanced Dynaudio sound quality into the vehicle.

Thus the same core technologies that have made Dynaudio one of the most renowned high end home audio loudspeaker brands, or the official professional studio monitor of the demanding BBC (British Broadcasting Corporation) have been implemented into a full range of high performance loudspeakers designed and optimized for in-car installation: the Dynaudio Esotec series.

The Dynaudio Esotec Automotive loudspeaker series exudes all of the virtues in Dynaudio's long-standing tradition of high performance loudspeaker designs: Highly-evolved Dynaudio technology, meticulously selected components, painstakingly matched materials and carefully voiced sonics.

Every technical detail is developed and manufactured exclusively by Dynaudio in the company's state-of-the-art production facility in Skanderborg, Denmark. Dynaudio loudspeaker systems exhibit no sonic character other than that of the recording, and are renowned for their ability to portray an accurate, uncolored reproduction of music. Music the way it was intended to be heard.

Dynaudio has become one of the world's leading high-end audio companies by staying true to the company vision of natural, uncompromised sound quality. The company's extreme focus and dedication as a specialist loudspeaker manufacturer is embodied in the diverse range of high-performance loudspeaker products.

The Dynaudio Esotec mobile loudspeakers follow in the longstanding tradition of the company's renowned home audio driver designs.

The new Esotec MD 102 tweeter is a soft-dome design as characteristic of Dynaudio. The fine soft dome features a special coating to facilitate an extended high frequency response free of distortion. The compact, shallow depth MD 102 tweeter features a 28 mm (1.1 inch) diameter surface area that is approximately 60% greater than that of conventional car audio tweeters. The optimized dome geometry provides greatly improved dispersion characteristics, enabling the MD 102 tweeter to offer exceptional performance even when mounted off of the listening axis. The dome coating serves to eliminate any high frequency break-ups, while providing improved damping. To eliminate high frequency distortions caused by reflections from inside the structure, the MD 102 tweeter rear chamber is also sealed and acoustically damped to eliminate high frequency distortion, which could be caused by back-wave reflections, while ferrofluid cooling adds damping and additional power handling.

The extremely smooth and incredibly detailed high frequency reproduction characteristic of the Dynaudio sound is ensured by the all-new Esotec soft-dome tweeter, which features the latest Dynaudio technological innovations. For the most authentic high-frequency reproduction – powerful Neodymium – one of the most efficient but also most expensive magnetic materials for loudspeaker construction is used in the tweeter magnet systems.

The soft-dome tweeter design topology allows unrestricted dynamics and a linear frequency response with extremely low distortion. The MD 102 features an aluminum voice coil, another Dynaudio hallmark, which has been updated and improved via an increased coil height with additional windings to allow an increased range of linear excursion within the magnetic field. Furthermore, as a result of the low moving mass of the new voice coil, a higher maximum output level and increased dynamics are achieved, while the frequency range has been expanded, thus allowing a better integration with the upper midrange frequencies to deliver a more natural sound with an open and detailed, and incredibly transparent reproduction of the high frequencies.

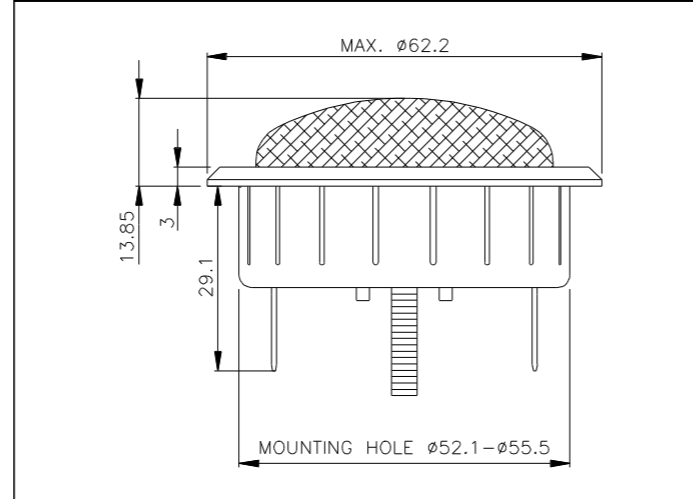

Thiele Small Parameters		
Nominal impedance	Znom	8 Ω
DC resistance	Re	5.6 Ω
Voice coil inductance	Le	- mH
Resonance frequency	fs	1300 Hz
Mechanical Q factor	Qms	-
Electrical Q factor	Qes	-
Total Q factor	Qts	-
Mechanical resistance	Rms	- kg/s
Moving mass (incl. air load)	Mms	- g
Suspension compliance	Cms	- mm/N
Effective dome diameter	d	- mm
Effective piston area	Sd	7.7 cm ²
Equivalent volume	Vas	- l
Force factor	BL	- Tm
Recommended frequency range		2200–30000 Hz

Magnet and Voice Coil Properties		
Voice coil diameter	dc	28 mm
Voice coil height	hc	1.7 mm
Linear excursion, peak to peak		- mm
Max. excursion, peak to peak		- mm

Power Handling		
Nominal long term IEC		100 W
Transient (10 ms)		500 W

Mechanical Properties		
Net weight		0.126 kg
Overall dimension		ø 62.2 x 43 mm

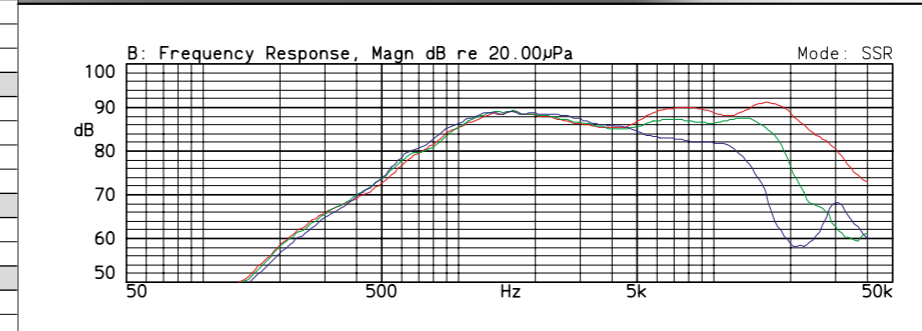
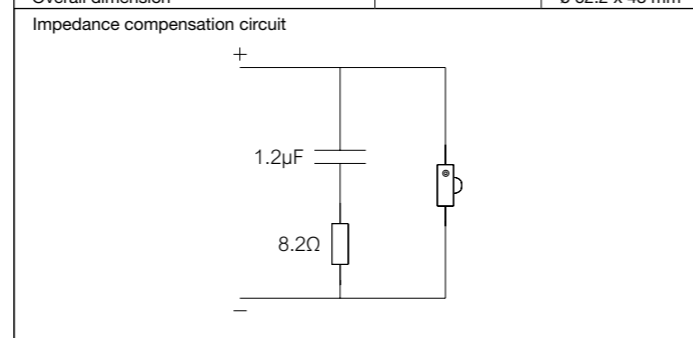

SPL
 Red line: on-axis response
 Green line: 30° horizontal
 Blue line: 60° horizontal
 Measurement conditions:
 Level: 2.83 V
 Distance: 1 m
 Measured in a large baffle

Facts
 Coated textile dome eliminates any high frequency break-ups
 Powerful neodymium magnet system
 Protective grille
 Open and detailed high frequency reproduction
 Damped cavity beneath the dome

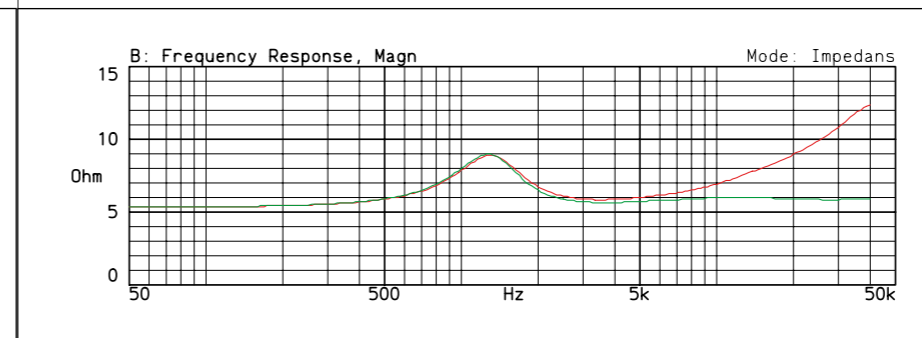

Impedance
 (with and without impedance correction circuit)
 Red line: impedance, free air
 Green line: impedance, free air with compensation.
 Measurement conditions:
 Level: 3.16 V, 50 ohm
 Driver in free air

Ferrofluid adds damping and increases power handling
 Aluminium voice coil wire results in a low moving mass
 Shallow mounting depth
 Strong 6.4 mm terminals

Similar to the MD 102 tweeter in principle, the new Esotec MD 142 is a 75mm (3-inch) diameter soft dome midrange design intended for high performance three- and four-way audio systems.

As typical of all Dynaudio tweeters and soft-dome midrange units, the MD 142 features a large diameter aluminum voice coil with a centered magnet housed in a relatively compact and shallow enclosure. Suspended in ferrofluid for controlled damping, an extremely light aluminium voice coil drives the dome. Aluminium has proven to be an ideal material for Dynaudio's oversized voice coils due to its extremely low mass, which in turn allows a larger coil diameter and more windings as compared to conventional designs. The heat produced by the voice coil is dissipated to the magnet system with the help of ferrofluid cooling liquid. The precisely optimized dome geometry and the low mass of the internal moving parts ensure a very transparent and detailed reproduction of all frequencies. In most dome driver designs, the surround of the driver and the outer edge of the driver membrane are moving in opposite phase and canceling each other's output at various frequencies. Dynaudio has undertaken extensive research into the shaping of these parts to ensure that the long linear excursions essential to high output levels are maintained without this type of interference.

The Esotec MD 142 is housed in a compact self-contained enclosure with a vented pole piece and damped rear chamber. It includes an integrated protective grille, and requires no additional airspace for installation. It thus may easily be integrated into a wide range of install applications and locations, including kick-panel, in-dash, in-door or rear deck mount placement. In tandem with the incredibly powerful Neodymium magnet, the sound reproduced by the MD 142 is smooth, detailed, dynamic and simply amazing.

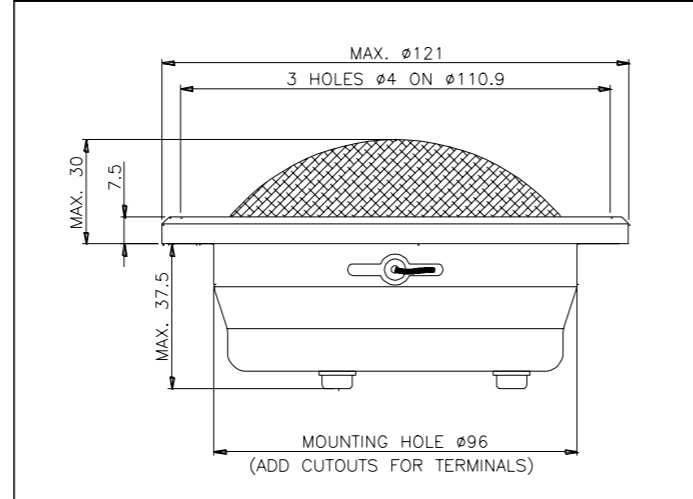

Thiele Small Parameters		
Nominal impedance	Znom	8 Ω
DC resistance	Re	5.3 Ω
Voice coil inductance	Le	- mH
Resonance frequency	fs	475 Hz
Mechanical Q factor	Qms	-
Electrical Q factor	Qes	-
Total Q factor	Qts	-
Mechanical resistance	Rms	- kg/s
Moving mass (incl. air load)	Mms	- g
Suspension compliance	Cms	- mm/N
Effective dome diameter	d	- mm
Effective piston area	Sd	52 cm ²
Equivalent volume	Vas	- l
Force factor	BL	- Tm
Recommended frequency range		700-6000 Hz

Magnet and Voice Coil Properties		
Voice coil diameter	dc	75 mm
Voice coil height	hc	5.5 mm
Linear excursion, peak to peak		2.5 mm
Max. excursion, peak to peak		5 mm

Power Handling		
Nominal long term IEC		100 W
Transient (10 ms)		1000 W

Mechanical Properties		
Net weight		0.75 kg
Overall dimension		ø 121 x 66 mm

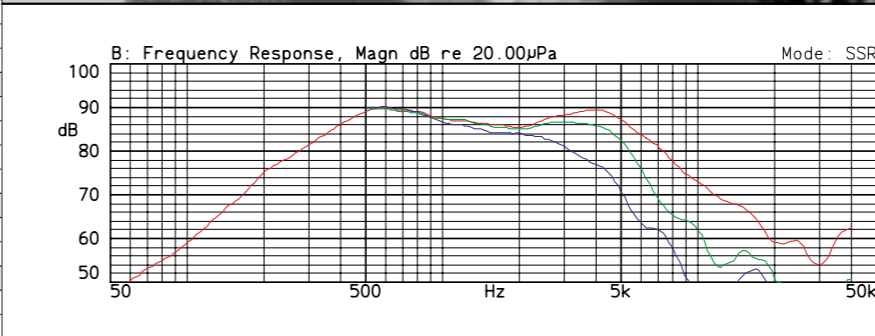
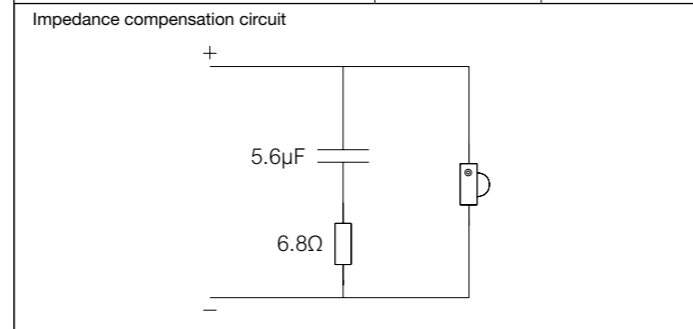

SPL

Red line: on-axis response
 Green line: 30° horizontal
 Blue line: 60° horizontal

Measurement conditions:
 Level: 2.83 V
 Distance: 1 m
 Measured in a large baffle

Facts

- Coated textile dome
- Large 75 mm voice coil ensures high power handling and low compression
- Internal magnet structure with vented pole piece
- Aluminium voice coil wire results in a low moving mass

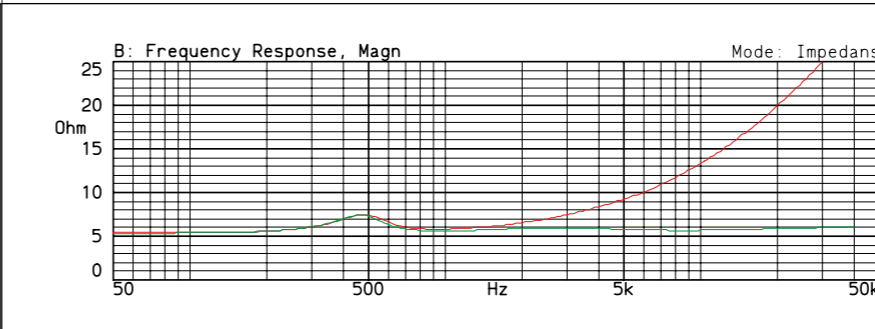

Impedance
 (with and without impedance correction circuit)

Red line: impedance, free air
 Green line: impedance, free air with compensation.

Measurement conditions:
 Level: 3.16 V, 50 ohm
 Driver in free air

- Shallow mounting depth
- Integrated protective grille
- Ferrofluid adds damping and increases power handling

The Dynaudio Esotec mid/woofers also utilize the same core technology as the company's home audio and professional studio loudspeaker products, with materials and parameters fully optimized for the particular conditions typical of in-car installations. All Esotec models are available in various sizes, all characterized by an ultra linear frequency response and Dynaudio's exemplary sonic performance.

The most compact of the new Esotec car series mid/woofers, the new MW 152 is a compact 15 cm (5.75 inch) diameter driver with a 75 mm (3 inch) diameter voice coil. As is the case with the full range of Dynaudio woofers, the cone diaphragm is composed of a proprietary MSP (magnesium silicate polymer) material developed by Dynaudio – a low-distortion material characterized by a lack of coloration that proves essential to the unique Dynaudio sound. The MW 152 exhibits a smooth frequency response both on- and off-axis, with incredibly low distortion. The MW 152 delivers excellent midrange reproduction and is the perfect choice for any small, high-performance two- or three-way system.

The woofer motor assemblies of the Esotec mid/woofers are built into torsionally rigid die-cast aluminium baskets (a high-strength stamped steel basket is utilized on the MW 162 GT and MW 182 model variants), which have been optimized to eliminate air turbulence and resonance and the adverse effects of such. The aerodynamically shaped ribs of the Dynaudio die cast driver frames serve to eliminate virtually all reflections and tonal aberrations created by the traditional driver frame, and ensure the highest degree of mechanical performance at an extremely low weight.

The low suspension compliance of the MW 152 makes it perfectly suited for smaller enclosures typical of most in-car installations, while also allowing it to be utilized without a dedicated enclosure in free-air mounting applications.

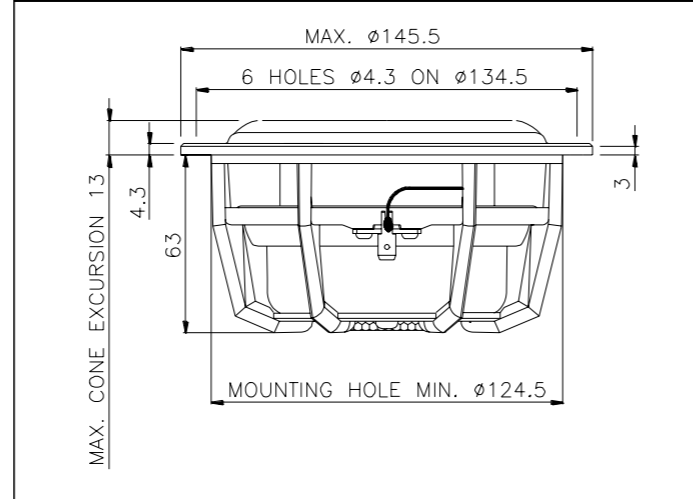

Thiele Small Parameters		
Nominal impedance	Znom	4 Ω
DC resistance	Re	3.0 Ω
Voice coil inductance	Le	0.24 mH
Resonance frequency	fs	70 Hz
Mechanical Q factor	Qms	1.9
Electrical Q factor	Qes	0.63
Total Q factor	Qts	0.47
Mechanical resistance	Rms	3.1 kg/s
Moving mass (incl. air load)	Mms	14 g
Suspension compliance	Cms	0.38 mm/N
Effective dome diameter	d	105 mm
Effective piston area	Sd	87 cm ²
Equivalent volume	Vas	4 l
Force factor	BL	5.4 Tm
Recommended frequency range		55–3500 Hz

Magnet and Voice Coil Properties		
Voice coil diameter	dc	75 mm
Voice coil height	hc	10.9 mm
Linear excursion, peak to peak		6 mm
Max. excursion, peak to peak		15 mm

Power Handling		
Nominal long term IEC		100 W
Transient (10 ms)		1000 W

Mechanical Properties		
Net weight		1.1 kg
Overall dimension		ø 145.5 x 70 mm

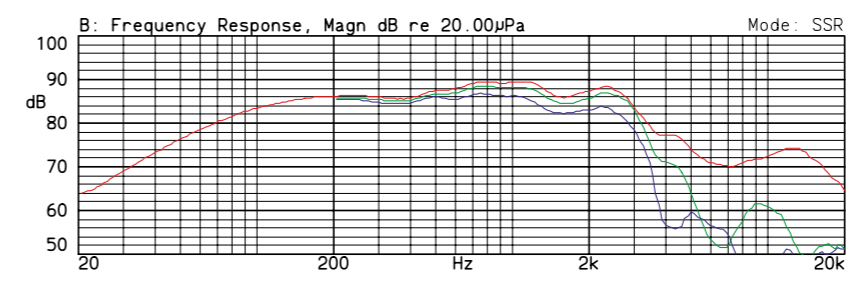
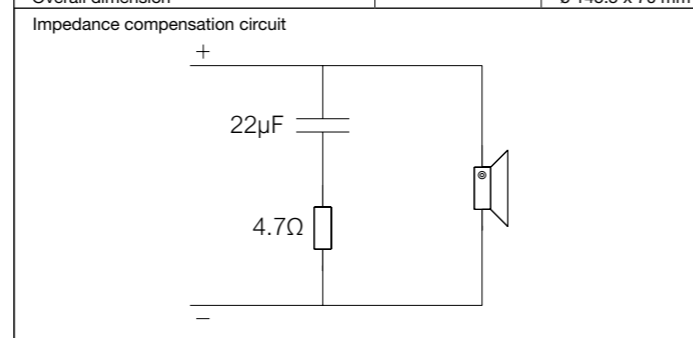

SPL
(Frequency response: on-axis, 30° and 60° off-axis)
Red line: on-axis response
Green line: 30° horizontal
Blue line: 60° horizontal
Measurement conditions:
Level: 2.83 V
Distance: 1 m
Box volume: 8.4 l

Facts
Diaphragm and dust cap moulded as one piece
Large 75 mm voice coil ensures high power handling
Internal double magnet system with vented pole piece
Aluminium voice coil wire provides for a low moving mass

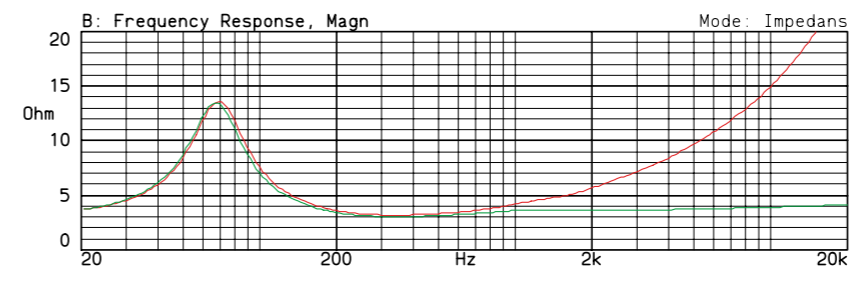

Impedance
(with and without impedance correction circuit)
Red line: impedance, free air
Green line: impedance, free air with compensation.
Measurement conditions:
Level: 2 V, 10 ohm
Driver in free air

Rigid die-cast chassis with aerodynamically shaped ribs
Materials and parameters are optimized for the harsh environmental conditions in a car
Smooth high-frequency roll-off

The Esotec MW 162 mid/woofer is a medium sized 17 cm (6.5 inch) diameter driver that combines a clear and detailed midrange with a strong and powerful bass response.

Another characteristic typical of Dynaudio drivers and carried through in the new Esotec mobile series woofers is the diffraction-optimized shape of the MSP cone's characteristic curvature, which further improves imaging so that even at short listening distances as typical of most in-car installations a realistic, true three-dimensional sound-stage can be enjoyed. Molding the diaphragm and dust cap into a one-piece flat-membrane results in a controlled roll off and high dynamic range. In relation to the total cone surface area, the 75 mm (3 inch) voice coil is exceptionally large in diameter, allowing a most precise conversion of the amplifier's signal to music. The result is un-compromised, direct music enjoyment.

All of the Esotec MW (mid/woofer) model variants employ Dynaudio's customary oversized aluminium voice coil, which feature an uncharacteristically large diameter coil wound on a strong and temperature stable former to drive the geometrically optimized rigid MSP cone diaphragm. The Esotec mid/woofers have all been further upgraded with a brand-new suspension. The new spider allows greater mechanical movement of the cone, increasing excursion while allowing a higher maximum SPL and improved low bass performance.

The use of Dynaudio's large diameter aluminium voice coils increases thermal handling capabilities tremendously, allowing the drivers to operate within an ideal temperature range, even at high continuous power levels and during powerful music transients. Dynamic impulses are reproduced precisely and without distortion, even at high volume levels, while impressive sound quality and high power handling capability are achieved.

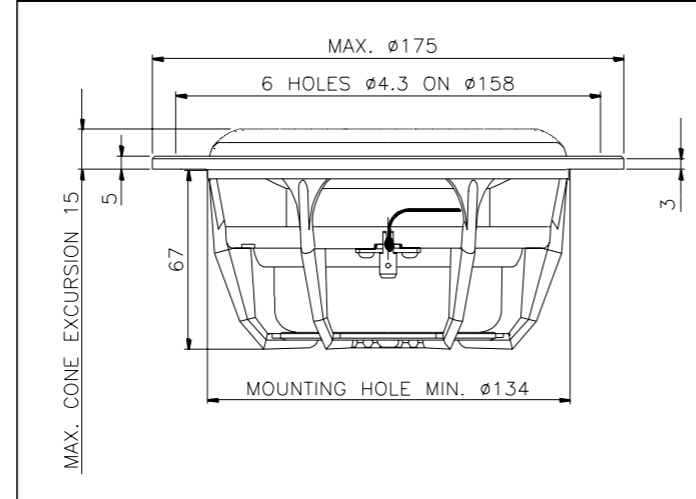

Thiele Small Parameters		
Nominal impedance	Znom	4 Ω
DC resistance	Re	3.1 Ω
Voice coil inductance	Le	0.22 mH
Resonance frequency	fs	55 Hz
Mechanical Q factor	Qms	2.2
Electrical Q factor	Qes	0.57
Total Q factor	Qts	0.45
Mechanical resistance	Rms	2.7 kg/s
Moving mass (incl. air load)	Mms	17.4 g
Suspension compliance	Cms	0.48 mm/N
Effective dome diameter	d	124 mm
Effective piston area	Sd	120 cm²
Equivalent volume	Vas	9.8 l
Force factor	BL	5.7 Tm
Recommended frequency range		40–4000 Hz

Magnet and Voice Coil Properties		
Voice coil diameter	dc	75 mm
Voice coil height	hc	10.9 mm
Linear excursion, peak to peak		6 mm
Max. excursion, peak to peak		17 mm

Power Handling		
Nominal long term IEC		120 W
Transient (10 ms)		1000 W

Mechanical Properties		
Net weight		1.2 kg
Overall dimension		Ø 175 x 77 mm

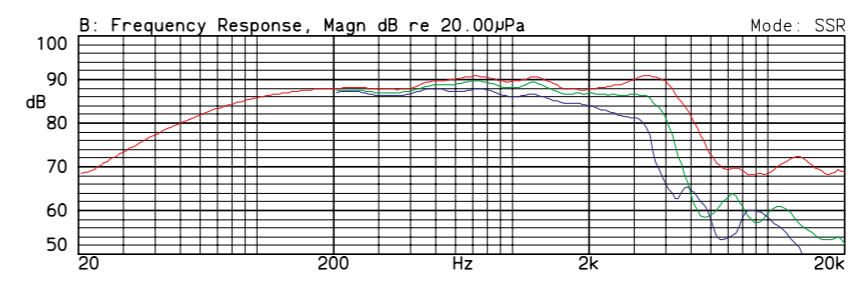
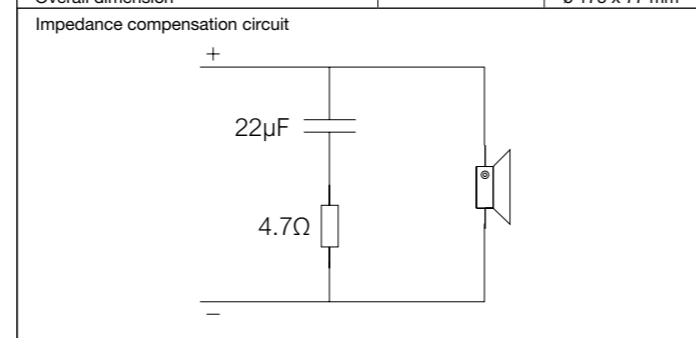

SPL
(Frequency response: on-axis, 30° and 60° off-axis)
Red line: on-axis response
Green line: 30° horizontal
Blue line: 60° horizontal
Measurement conditions:
Level: 2.83 V
Distance: 1 m
Box volume: 15.6 l

Facts
Diaphragm and dust cap moulded as one piece
Large 75 mm voice coil ensures high power handling
Internal double magnet system with vented pole piece
Aluminium voice coil wire provides for a low moving mass

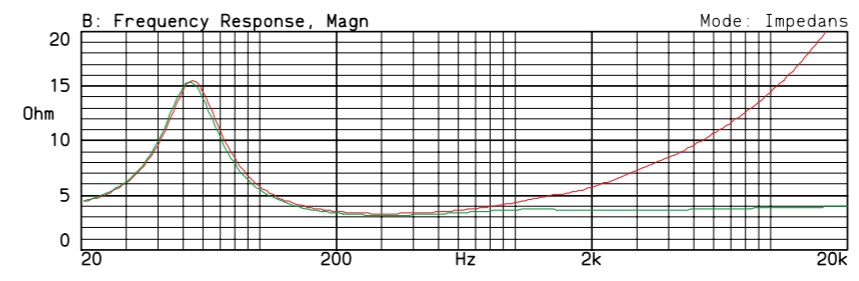

Impedance
(with and without impedance correction circuit)
Red line: impedance, free air
Green line: impedance, free air with compensation.
Measurement conditions:
Level: 2 V, 10 ohm
Driver in free air

Rigid die-cast chassis with aerodynamically shaped ribs
Materials and parameters are optimized for the harsh environmental conditions in a car
Smooth high-frequency roll-off
Natural midrange reproduction

The new Esotec MW 162 GT is a smaller version of the MW 162 mid/bass driver, also a 17 cm (6.5 inch) diameter design with a 75 mm (3 inch) voice coil, housed in a slightly more compact yet rigid stamped steel basket to better allow it to fit into a wider range of drop-in factory automobile loudspeaker locations.

This is especially helpful in minimizing labor by eliminating otherwise necessary vehicle modifications during installations where space is limited. The Esotec mobile loudspeaker woofers all use glued and thermally bonded styrene butadiene rubber surrounds, which ensure excellent control and reliability, while providing added durability against the elements.

For more dynamic power delivery in the bass region, the 15, 17 and 20 cm diameter Esotec mid/bass drivers employ Dynaudio's traditional double-magnet motor system while featuring new, upgraded high-density ultra-compressed Ferrite magnets. The new magnet systems provide an extremely controlled and incredibly precise movement of the voice coil. The result is improved dynamics and greater fidelity to the original music signal. Dramatic musical passages are thus reproduced accurately and without compromise. And with increased cone excursion, even the most powerful transients are delivered without compression.

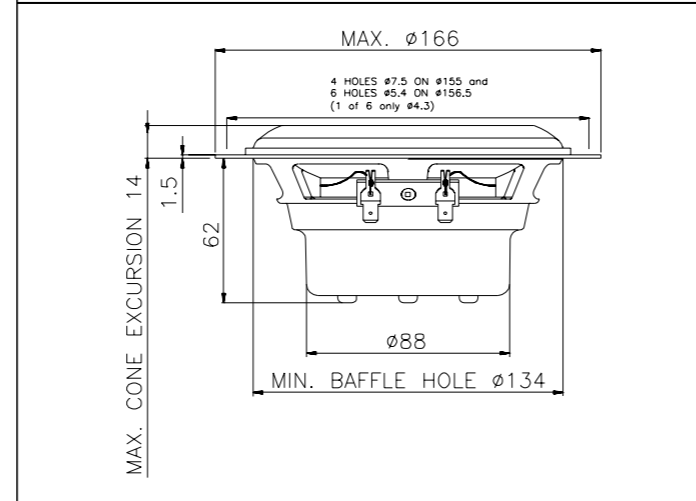

Thiele Small Parameters		
Nominal impedance	Znom	4 Ω
DC resistance	Re	3.0 Ω
Voice coil inductance	Le	0.22 mH
Resonance frequency	fs	60 Hz
Mechanical Q factor	Qms	2.1
Electrical Q factor	Qes	0.63
Total Q factor	Qts	0.48
Mechanical resistance	Rms	3 kg/s
Moving mass (incl. air load)	Mms	16.8 g
Suspension compliance	Cms	0.42 mm/N
Effective dome diameter	d	124 mm
Effective piston area	Sd	120 cm²
Equivalent volume	Vas	8.6 l
Force factor	BL	5.5 Tm
Recommended frequency range		40–4000 Hz

Magnet and Voice Coil Properties		
Voice coil diameter	dc	75 mm
Voice coil height	hc	10.9 mm
Linear excursion, peak to peak		6 mm
Max. excursion, peak to peak		17 mm

Power Handling		
Nominal long term IEC		120 W
Transient (10 ms)		1000 W

Mechanical Properties		
Net weight		1.1 kg
Overall dimension		ø 166 x 71 mm

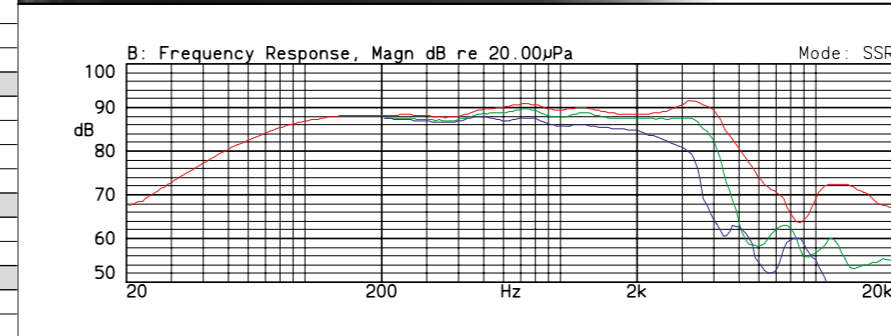
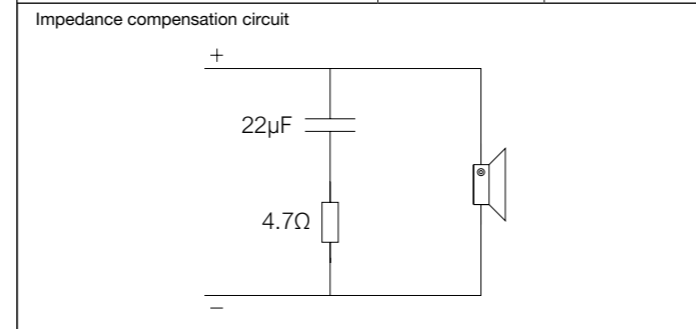

SPL

Red line: on-axis response
Green line: 30° horizontal
Blue line: 60° horizontal

Measurement conditions:
Level: 2.83 V
Distance: 1 m
Box volume: 15.6 l

Facts

- Diaphragm and dust cap moulded as one piece
- Large 75 mm voice coil ensures high power handling
- Internal double magnet system with vented pole piece
- Aluminium voice coil wire provides for a low moving mass

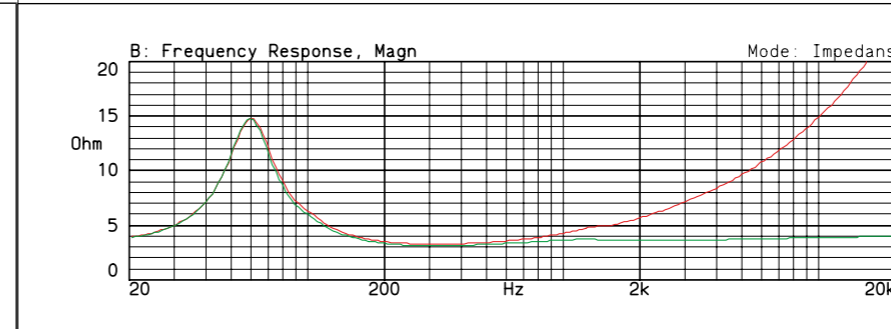

Impedance
(with and without impedance correction circuit)

Red line: impedance, free air
Green line: impedance, free air with compensation.

Measurement conditions:
Level: 2 V, 10 ohms
Driver in free air

Materials and parameters are optimized for the harsh environmental conditions in a car

- Smooth high-frequency roll-off
- Natural midrange reproduction

The new Esotec MW 172 is a 20 cm (8 inch) diameter mid/woofer designed for high performance two-and three way systems.

The MW 172 will perform extremely well in a wide range of enclosures, either sealed, vented, or free-air. The MW 172 exhibits a unique combination of smooth frequency response, low distortion, and extremely powerful bass to deliver an outstanding sonic performance in any high performance two- or three-way system.

The MW 172 utilizes an oversized 75 mm (3 inch) diameter voice coil to drive the MSP one-piece cone diaphragm. The new 15, 17 and 20 cm Esotec car series woofers all utilize new ultra compressed dual ferrite magnets positioned inside the coil to produce maximum utilization of the magnetic energy. The powerful double magnet system utilizes a vented pole piece for additional cooling. Positioning the magnet structure inside the voice coil enables the use of a very large voice coil, which in turn produces increased power and efficiency and yields a linear movement of the cone without cone breakup. Phase response is smooth and uniform. The large diameter of the voice coils provides optimum drive of the diaphragm and guarantees enough headroom with regard to power rating, while assuring perfect control of even the most minute membrane displacement. The use of a large diameter voice coil also allows for the flat Dynaudio MSP cone membrane geometry, which results in minimal phase lag at crossover to midrange driver.

The MW 172 is a perfectly balanced driver with excellent dispersion, a linear frequency response and an extraordinary absence of resonance, rendering it ideal for anchoring even a high quality two-way system even with its relatively large cone diameter.

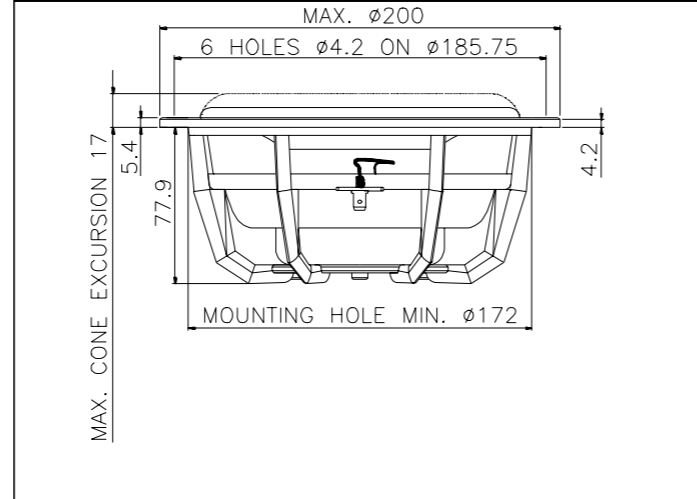

Thiele Small Parameters		
Nominal impedance	Znom	4 Ω
DC resistance	Re	3.2 Ω
Voice coil inductance	Le	0.27 mH
Resonance frequency	fs	45 Hz
Mechanical Q factor	Qms	2.3
Electrical Q factor	Qes	0.65
Total Q factor	Qts	0.51
Mechanical resistance	Rms	2.6 kg/s
Moving mass (incl. air load)	Mms	21.4 g
Suspension compliance	Cms	0.58 mm/N
Effective dome diameter	d	151 mm
Effective piston area	Sd	180 cm²
Equivalent volume	Vas	27 l
Force factor	BL	5.4 Tm
Recommended frequency range		35-3500 Hz

Magnet and Voice Coil Properties		
Voice coil diameter	dc	75 mm
Voice coil height	hc	14 mm
Linear excursion, peak to peak		9 mm
Max. excursion, peak to peak		15 mm

Power Handling		
Nominal long term IEC		150 W
Transient (10 ms)		1000 W

Mechanical Properties		
Net weight		1.6 kg
Overall dimension		ø 200 x 88 mm

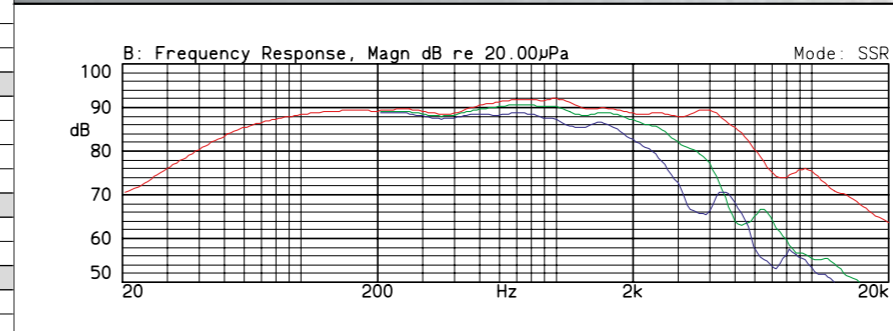
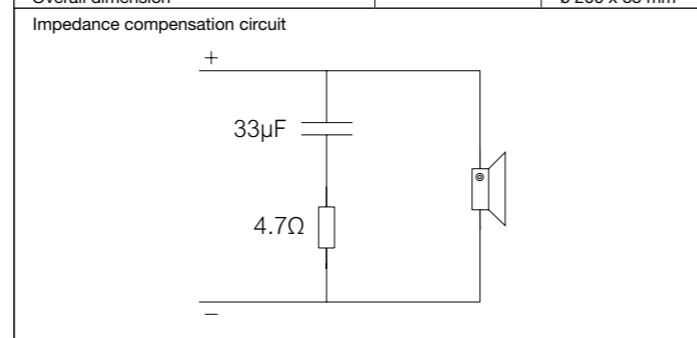

SPL
 Red line: on-axis response
 Green line: 30° horizontal
 Blue line: 60° horizontal
 Measurement conditions:
 Level: 2.83 V
 Distance: 1 m
 Box volume: 18 l

Facts
 Diaphragm and dust cap moulded as one piece
 Very large 75 mm voice coil ensures high power handling
 Internal double magnet system with vented pole piece
 Aluminium voice coil wire provides for a low moving mass

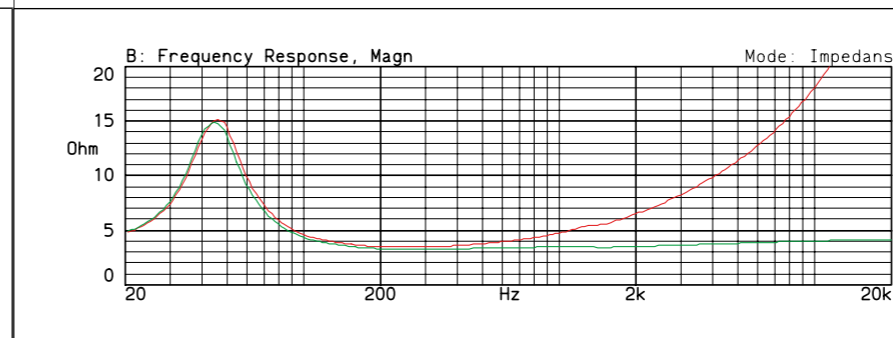

Impedance
 (with and without impedance correction circuit)
 Red line: impedance, free air
 Green line: impedance, free air with compensation.
 Measurement conditions:
 Level: 2 V, 10 ohm
 Driver in free air

Rigid die-cast chassis with aerodynamically shaped ribs
 Materials and parameters are optimized for the harsh environmental conditions in a car
 Natural midrange reproduction
 Smooth high-frequency roll-off

The new Esotec MW 182 is a large 24 cm (10 inch) diameter mid/woofer equipped with an extremely large, 100 mm (4 inch) diameter voice coil with a dual centered magnet system driving the MSP cone to ensure the greatest possible power handling. This impressive driver is ideally suited for woofer or subwoofer applications in any high quality car audio system.

To achieve the lowest possible moving mass, as is the case with all Dynaudio voice coil designs, the unique oversized voice coils are made of pure aluminum while the voice coil wire is itself wound in Dynaudio's proprietary technique. Via an inimitable winding method, the lightweight aluminum coils are coated with a special thermoplastic material. The coils are then processed in such a way that the coil expands and contracts until the wires have reformed into a solid mass of wire. By this method, an extremely durable and stable coil is made, one not subject to warping and other problems commonly associated with traditional loudspeaker voice coils. Concurrently, the density of the winding within the magnetic gap is increased, as is the efficiency of the driver.

The MW 182 is suited for a wide array of installation enclosures, both sealed as well as vented. The long linear excursion of the ultra low distortion MSP cone is perfectly complemented by the mechanical integrity of the rigid steel basket. In conjunction with the extremely large voice coil, the MW 182 delivers not only high power handling but also a deep, tight and detailed reproduction of bass free of any compression.

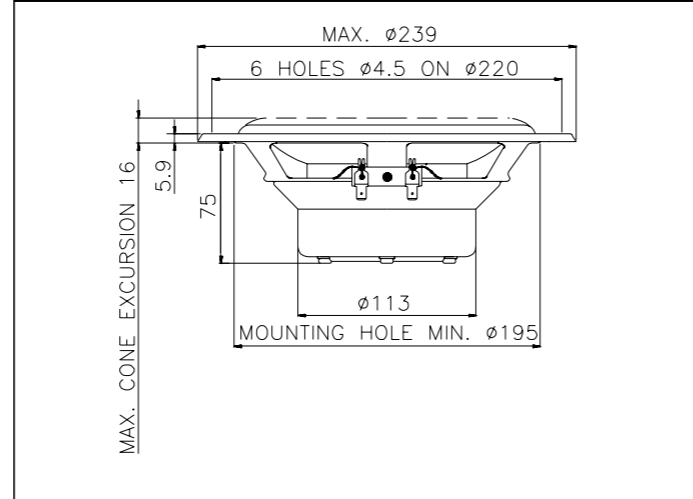

Thiele Small Parameters		
Nominal impedance	Znom	4 Ω
DC resistance	Re	3.7 Ω
Voice coil inductance	Le	0.5 mH
Resonance frequency	fs	40 Hz
Mechanical Q factor	Qms	2.8
Electrical Q factor	Qes	0.84
Total Q factor	Qts	0.64
Mechanical resistance	Rms	3.3 kg/s
Moving mass (incl. air load)	Mms	36.5 g
Suspension compliance	Cms	0.43 mm/N
Effective dome diameter	d	173 mm
Effective piston area	Sd	235 cm²
Equivalent volume	Vas	34 l
Force factor	BL	6.4 Tm
Recommended frequency range		30-2000 Hz

Magnet and Voice Coil Properties		
Voice coil diameter	dc	100 mm
Voice coil height	hc	17 mm
Linear excursion, peak to peak		9 mm
Max. excursion, peak to peak		26 mm

Power Handling		
Nominal long term IEC		180 W
Transient (10 ms)		1000 W

Mechanical Properties		
Net weight		1.85 kg
Overall dimension		Ø 239 x 86 mm

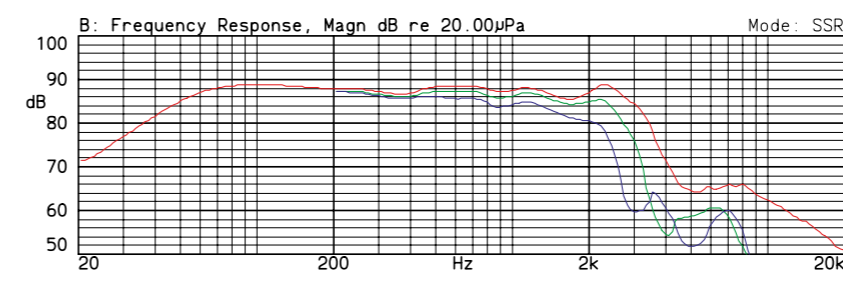
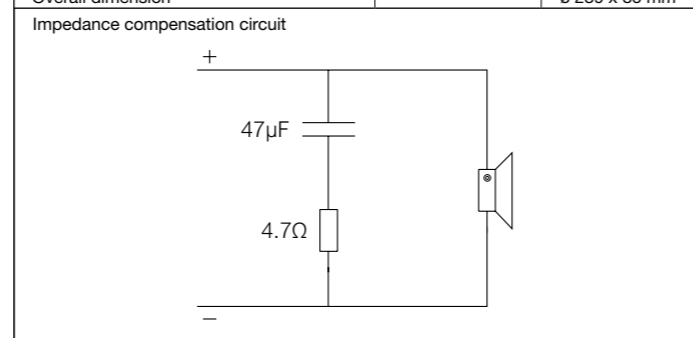

SPL
 Red line: on-axis response
 Green line: 30° horizontal
 Blue line: 60° horizontal
 Measurement conditions:
 Level: 2.83 V
 Distance: 1 m
 Box volume: 25 l

Facts
 Diaphragm and dust cap moulded as one piece
 Very large 100 mm voice coil ensures high power handling
 Internal magnet structure with vented pole piece
 Long linear excursion

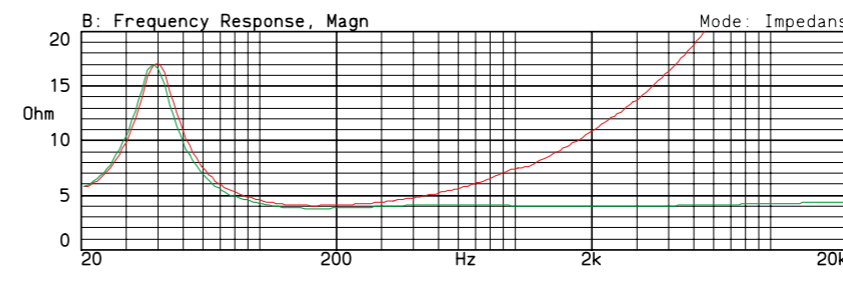

Impedance
 Red line: impedance, free air
 Green line: impedance, free air with compensation
 Measurement conditions:
 Level: 2 V, 10 ohm
 Driver in free air

Aluminium voice coil wire provides for a low moving mass
 Materials and parameters are optimized for the harsh environmental conditions in a car

Crossover Esotec X 252

The new Esotec X 252 crossover is a competition grade, audiophile quality passive two-way crossover designed to accommodate four of the new Esotec woofers, the MW 152, MW 162, MW 162 GT and MW 172 models in combination with the Esotec MD 102 tweeter.

The X 252 Crossover is also included in three packaged Esotec two-way component systems, and features a three-position tweeter level control to better adjust the high frequency performance to listener position or preference. With the vast experience gained in developing the advanced Dynaudio premium factory sound systems offered to the automotive industry, fine-tuning the new Esotec crossovers brought forth a substantial improvement in sound quality. The Esotec X 252 is a first order crossover with impedance correction for the woofer to create an even easier load for any amplifier and a second order filter with an integrated self-resetting protection circuit for the tweeter. The Esotec crossovers all feature gold plated screw terminals, polypropylene capacitors, thick printed circuit boards with pure copper traces, and are housed in impact resistant plastic enclosures. Each is optimized for a particular configuration and is designed to enable the individual Esotec loudspeaker models to perform at their optimum capabilities while addressing a wide range of systems and applications, and are optimized for perfect phase response and time coherency in any vehicle.



X 252	MW 152	MW 162/GT	MW 172
Crossover frequency	2200 Hz	2200 Hz	2200 Hz
Nominal impedance	4 Ohms	4 Ohms	4 Ohms
Power handling	100 W	120 W	150 W
Dimensions	38 x 84 x 145 mm		
Net weight	0.33 kg		



Crossover Esotec X 362

The new Esotec X 362 crossover is a three-way competition grade, audiophile quality passive crossover designed to accommodate four of the new Esotec woofers, the MW 162, MW 162 GT, MW 172 and MW 182 models in combination with the Esotec MD 102 tweeter and Esotec MD 142 soft dome midrange.

The X 362 Crossover is also included in two packaged Esotec three-way component systems. There is a three-position level control for both the tweeter and midrange, which allow one to adjust the sound according to driver position and or personal preference. Regardless of the driver complement chosen, the result is an incredibly linear frequency response with an extremely detailed midrange reproduction and excellent dispersion.

Essentially a three way variant of the X 252 model, the Esotec X 362 utilizes a first order crossover slope for the woofer and midrange, and a second order slope for the tweeter. The phase correct, shallow slope Esotec crossover networks utilize the highest quality components selected and matched to extremely tight tolerances and offer impedance correction for the woofer and integrated protection circuits for the tweeter while enabling a linear frequency response and improved dispersion from the drivers, allowing such to be perfectly integrated into any vehicle.

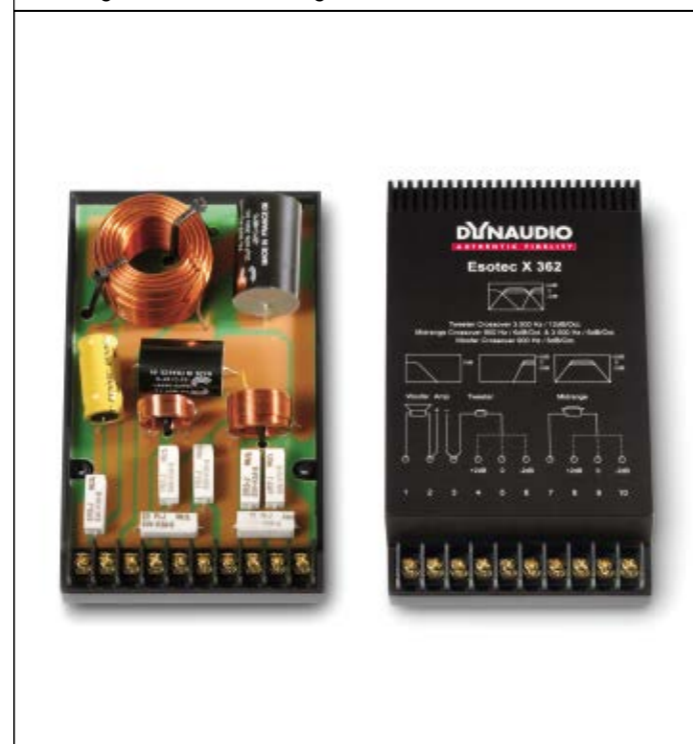

X 362	MW 162/GT	MW 172	MW 182
Crossover frequency	900 Hz/3.5 kHz	900 Hz/3.5 kHz	900 Hz/3.5 kHz
Nominal impedance	4 Ohms	4 Ohms	4 Ohms
Power handling	200 W	200 W	200 W
Dimensions	43 x 104 x 175 mm		
Net weight	0.60 kg		



Esotec System 222

While individual drivers are available separately to offer complete system building flexibility, Dynaudio has packaged the most popular two-way driver complements with audiophile quality, competition-grade, adjustable passive crossover networks into component system packages to deliver the new Esotec performance quality at the highest level of value possible.

The Esotec System 222 is a two-way component system comprising one pair each of MW 152 woofers, MD 102 tweeters and X 252 crossovers along with all mounting hardware and grilles.

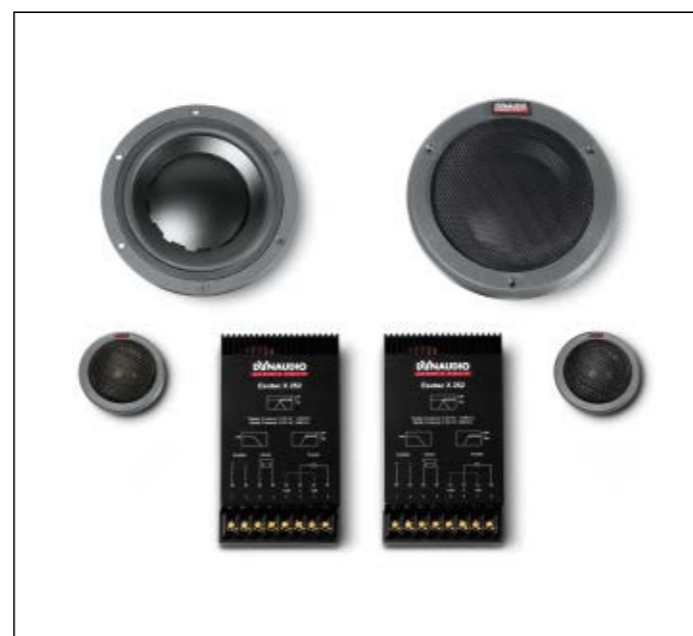

- Esotec System 222**
- Two-Way System
 - 5.75" MSP-Woofers, 1.1" Soft-Dome Tweeter
 - Frequency Response: 55 Hz – 25 kHz
 - Sensitivity: 91 dB
 - Continuous Power Handling: 200 Watts
 - System Impedance: 4 Ω



Esotec Grilles

The original Dynaudio Protection Grilles separately are available for every driver.

Their massive and indestructible finish will make sure your build-in drivers never get damaged. The tutelary metal-grid is uncritical in acoustical behaviour and can be mounted free of resonances with usual screws. With their unobtrusive surfacefinish the Dynaudio grilles can be integrated inconspicuously in almost every interior to guide every attention to the essential – just to the music!



- Esotec Grilles**
- Inherently stable
 - Acoustically permeable grid-structure
 - Including mounting-ring with Dynaudio Logo
 - Discreet anthracite varnish
 - Excluding corresponding screws



Esotec System 242

The Esotec System 242 is a two-way component system comprising one pair each of MW 162 woofers, MD 102 tweeters and X 252 crossovers along with all mounting hardware and grilles.

Dynaudio's Esotec component sets are designed to facilitate performance optimized system synergies offering an unprecedented level of sound quality and flexibility in a wide range of applications and vehicles. The new Esotec car series crossovers are impedance-corrected and truly linear, thus enabling a wide variety of power amplifiers to be ideally utilized to drive the entire range of Esotec loudspeaker models, allowing the full potential of the Dynaudio system to be realized – something essential for a perfectly harmonious and comprehensive system performance.



- Esotec System 242**
- Two-Way System
 - 7" MSP-Woofer, 1.1" Soft-Dome Tweeter
 - Frequency Response: 55 Hz – 25 kHz
 - Sensitivity: 90 dB
 - Continuous Power Handling: 100 Watts
 - System Impedance: 4 Ω



Esotec System 242 GT

The Esotec System 242 GT is a two-way component system comprising one pair each of MW 162 GT woofers, MD 102 tweeters and X 252 crossovers along with all mounting hardware and grilles.

In order to perfectly integrate the improved drivers, the Esotec component systems feature new crossover designs updated with optimized parameters. The balanced frequency response of the Dynaudio Esotec automotive loudspeaker series is not simply the result of the superior drivers utilized, but also a product of the accurate fine-tuning in the crossover.



- Esotec System 242 GT**
- Two-Way System
 - 7" MSP-Woofer, 1.1" Soft-Dome Tweeter
 - Frequency Response: 55 Hz – 25 kHz
 - Sensitivity: 90 dB
 - Continuous Power Handling: 100 Watts
 - System Impedance: 4 Ω



Esotec System 342

The Esotec System 342 three-way component system includes one pair each of the MD 102 soft-dome tweeter, MD 142 soft-dome midrange, MW 162 mid/woofer and X 362 audiophile quality, competition-grade, adjustable passive crossover networks into an ultra high performance package that delivers Dynaudio's advanced high fidelity sound and an incredible level of installation flexibility. All mounting hardware and grilles are included.

Taking the performance of the company's two-way systems one step further, Dynaudio's Esotec three-way systems incorporate the innovative MD 142 soft-dome midrange unit that adds a further sense of refinement to the system while offering such at the highest possible value.



- Esotec System 342**
- Three-Way System
 - 7" MSP-Woofer, 3" Soft-Dome Midrange, 1.1" Soft-Dome Tweeter
 - Frequency Response: 55 Hz – 25 kHz
 - Sensitivity: 91 dB
 - Continuous Power Handling: 200 Watts
 - System Impedance: 4 Ω



Esotec System 362

The Esotec System 362 component systems combine one pair each of the MD 102 soft-dome tweeter, MD 142 softdome midrange, MW 172 woofers and the X 362 crossover networks into an incredibly refined and ultimately powerful three-way component system. All mounting hardware and grilles are included.

The Dynaudio Esotec mobile loudspeakers are perfectly complemented by the company's various dedicated crossover offerings. The Esotec component system crossovers are truly competition grade, using the highest quality components throughout. Custom produced, hand-selected, top quality polypropylene capacitors and custom wound, high-grade air-core inductors are utilized, as are impedance correction networks and tweeter protection circuits and independent tweeter adjustment levels for added system set-up flexibility. Mated to the advanced technology Esotec car series loudspeakers, the net result is a system that delivers authentic Dynaudio sound quality with a neutral tonal balance, incredible imaging and sound-staging capabilities, unsurpassed dynamics and complete transparency.



- Esotec System 362**
- Three-Way System
 - 8" MSP-Woofer, 3" Soft-Dome Midrange, 1.1" Soft-Dome Tweeter
 - Frequency Response: 40 Hz – 25 kHz
 - Sensitivity: 92 dB
 - Continuous Power Handling: 200 Watts
 - System Impedance: 4 Ω



Volkswagen

Volkswagen searched for a real audio specialist – and in 2002 they turned to Dynaudio to develop a benchmark sound system for the next generation Passat. Inspiring owners and car magazine test drivers alike, the resulting high-end sound system redefined the level of sound quality from a factory-fitted stereo system. This tremendous success marked the beginning of a long-term collaboration between Dynaudio and Volkswagen.

Working closely with the Volkswagen development team, Dynaudio is involved in the design of the entire sound system from the very early stages. Being involved so early meant that the Dynaudio engineers could optimize the location, mounting, and housing of all components and precision-tailor the amplifiers and associated circuitry in order to achieve the best possible performance. The end result is a sound system that has been perfectly integrated, both sonically and aesthetically – discreet Dynaudio logos are the only visible clues.

The combination of ten Dynaudio loudspeaker drivers powered by state-of-the-art digital amplifiers using digital sound processing (DSP) technology provides a sound experience previously unheard of. This authentic sound quality is achieved by individually designing and adapting the loudspeakers and amplifiers for nearly all Volkswagen models.



Bugatti

An encounter of superlatives: for the first time, the performance of the legendary Dynaudio hi-fi and home cinema loudspeakers is transferred to a unique Super Sports car. When launched, the Bugatti Veyron set new benchmarks in engineering and performance for a Super Sports car, so when developing an audio system for the new Grand Sport only the best would do.

The all-new Puccini Sound System includes dedicated Dynaudio loudspeaker technology and a high-performance digital amplifier. With impressive dynamics and extraordinary musicality this system sets a new sound quality standard in the segment redefined by Bugatti.

In the Grand Sport Roadster the acoustic requirements were even higher than in the Bugatti Veyron 16.4, resulting in an advanced design of the new sound system that surpasses that of the Coupe by some margin.

The new Puccini Sound System is comprised of four Dynaudio loudspeaker drive units, perfectly integrated into the interior and acoustically optimized by the Dynaudio sound experts. Due to the compact interior dimensions and only two seats, Dynaudio limited the number of speakers and concentrated on the absolute attention to detail that is in keeping with a vehicle like the Grand Sport. The use and selection of advanced materials and amplification with digital signal processing is what makes this system exceptional.



All there is.

DYNAUDIO

Dynaudio A/S, 8660 Skanderborg, Denmark
www.dynaudio.com